

SEIT 1928

KONDENSATORMIKROFONE
FÜR STUDIO - UND MESSTECHNIK

MICROTECH GEFELL



DIFFUSE FIELD MICROPHONE

- extreme dynamic range
- low noise floor
- large membrane capsule
- advanced circuit design
- transformerless output
- high sensitivity
- compact design
- price right

STUDIO CONDENSER MICROPHONE

M 960 ○

STUDIO CONDENSER MICROPHONE M 960

High output level and low noise

M 960 with omni-directional pattern **diffuse field**

The M 960 studio condenser microphone combines well-proven large diaphragm capsule technology with the latest in semiconductor circuit topology.

It is specifically designed to meet the needs of professional and semi-professional users who demand the highest performance.

The M 960 is ideally suited for miking applications in broadcast and sound studios.

Applications include recordings outside the diffuse field distance during choir or orchestra performances, e.g. in concert halls, churches and theatres.

The pick-up pattern of the microphone is axial.

The condenser capsule is designed for a diffuse field. It exhibits a presence boost in the 4 to 12 kHz range.

The electronic impedance converter uses a newly perfected circuit topology. This design reduces the noise floor to an extremely low level while also raising the maximum output capability. As a result, this microphone has a clean, distortion-free sound over an extremely wide dynamic range.

The M 960 is either mounted by means of the microphone stand holder MH 93.1, which is included or the optional swivel mount MH 93. If necessary the microphone stand holder can be exchanged for the elastic suspension EH 93 to further attenuate noise (in extreme situations).

The M 960 connects to the microphone cable with a standard 3-pin XLR plug. Powering must be provided by an external 48 V phantom supply according to DIN EN 61938 and IEC 1938.

The microphone is finished in dark bronze.

ACCESSORIES, optional

Windscreen, anthracite	W 96
Elastic suspension, dark bronze	EH 93
Microphone holder, dark bronze	MH 93
Power supply	N 200
Microphone cable	C 70

M 960 with microphone holder MH 93.1



Order-No. 202412
Order-No. 202328
Order-No. 202326
Order-No. 202101
Order-No. 202212

TECHNICAL SPECIFICATIONS

CE Certificate		M 960	
Polar pattern	Omni-directional for diffuse field		
Acoustic operating principle	Pressure gradient transducer		
Frequency range, free field	20...20000	Hz	
Sensitivity at 1 kHz	16	mV/Pa	
Output impedance	100	Ω	
Noise level	CCIR 468-4	19	dB
	IEC 651	9	dB-A
Signal-to-noise ratio (re at 1 Pa at 1 kHz)	CCIR-weighted	75	dB
	A-weighted	85	dB
Max. SPL for THD < 0,5%		145	dB
Max. Output level	$R_L = 1\text{ k}\Omega$	17	dBu
	$R_L = 10\text{ k}\Omega$	18	dBu
Dynamic range of electronics		135	dB
Current consumption (P 48, DIN 45596, IEC 268-15)		3,6	mA
Output connector	3-pin XLR connector gold-plated contacts		
Weight without MH 93.1		220	g
Dimensions (L x \varnothing)		90 x 45	mm
Finish	Dark bronze		

DELIVERY

The microphone is delivered in a wooden case with microphone stand holder MH 93.1 L x B x H 180 x 106 x 78 mm

Order-No. 211171

Ordering example:



POLAR PATTERNS

FREQUENCY RESPONSE

diffuse field

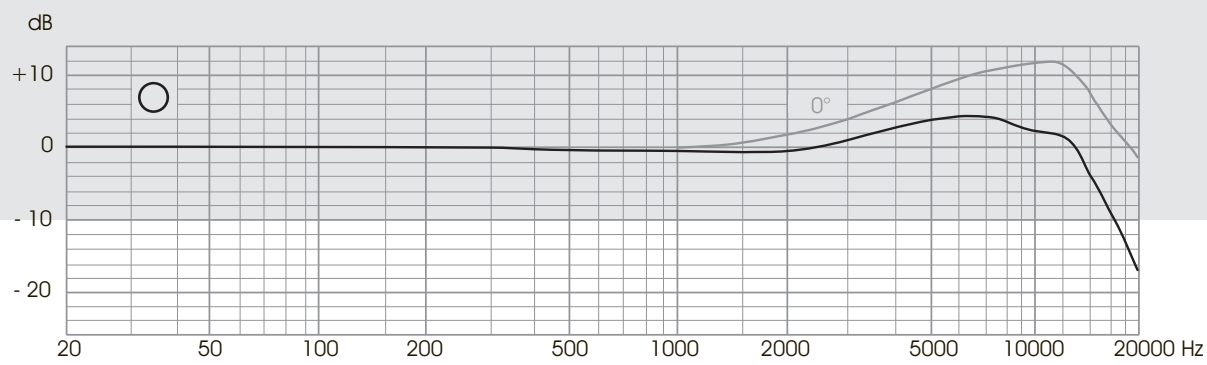

free field

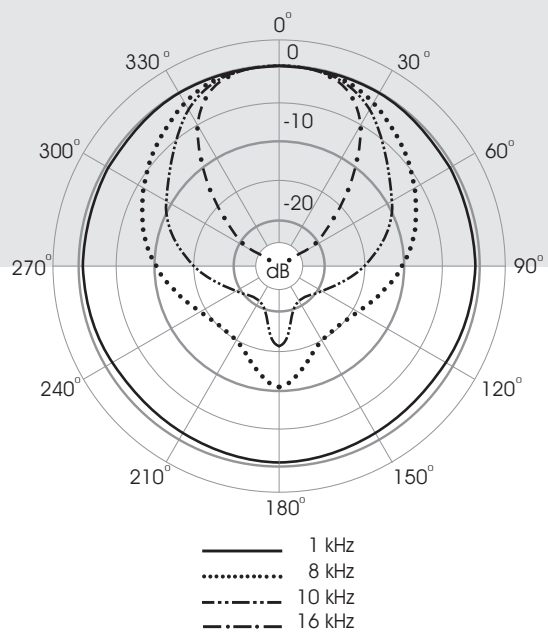
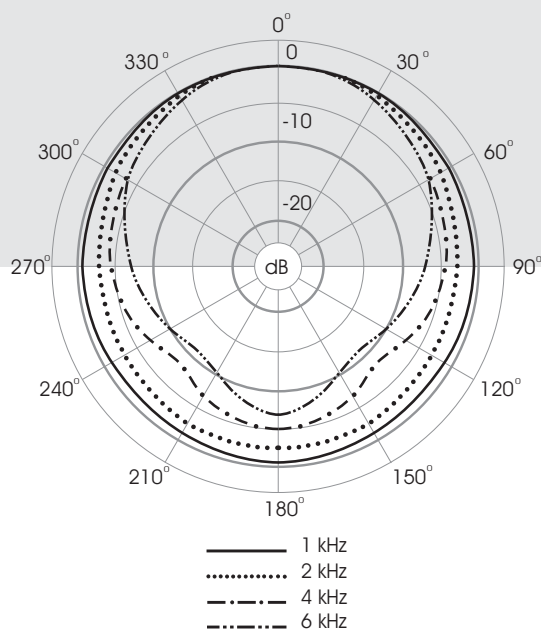

M 960

interstage
 Phistersvej 31, 2900 Hellerup, Danmark
 Telefon 3946 0000, fax 3946 0040
 www.interstage.dk
 - pro audio with a smile

