

GENELEC®

Operating Manual
7260A, 7270A and 7271A DSP Subwoofers



GENELEC

interstage

Phistersvej 31, 2900 Hellerup, Danmark
Telefon 3946 0000, fax 3946 0040
www.interstage.dk



- pro audio with a smile

INTRODUCTION

Congratulations and a thank-you for the purchase of this Genelec 7200 Series DSP Subwoofer. These systems are designed to integrate easily into the digital production environment. There are several ways to configure and operate the DSP subwoofers for a wide variety of high quality audio applications.

This manual addresses setting up and using the Genelec 7260A, 7270A and 7271A subwoofers with Genelec 8240A and 8250A DSP loudspeakers in stand-alone mode without the Genelec Loudspeaker Manager GLM™ and the proprietary Genelec loudspeaker control network. Use with the GLM™ network is described in the DSP System Operating Manual.

EC Declaration Of Conformity

This is to certify that Genelec 7260A, 7270A and 7271A DSP subwoofers conform to the following standards:

Safety: EN 60065: 2002 / IEC 60065:2001 7th Edition

EMC: EN 55020 : 2002 + A1 : 2003, EN 55013: (2001), EN 61000-3-2 (2000) and EN 61000-3-3 (1995)

The products herewith comply with the requirements of The Low Voltage Directive 73/23/EEC, EMC Directive 89/336/EEC and 93/68/EEC

Signed:

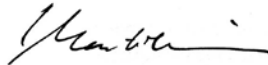

Ilpo Martikainen

Position: Chairman of the Board

Date: 20-February-2006

Compliance to FCC Rules

This device complies with part 15 of the FCC Rules. Operation is subject to the following two conditions:

- This device may not cause harmful interference, and
- This device must accept any interference received, including interference that may cause undesired operation.

Note: This equipment has been tested and found to comply with the limits for a Class B digital device, pursuant to part 15 of the FCC Rules. These limits are designed to provide reasonable protection against

harmful interference in a residential installation. This equipment generates, uses and can radiate radio frequency energy and, if not installed and used in accordance with the instructions, may cause harmful interference to radio communications. However, there is no guarantee that interference will not occur in a particular installation. If this equipment does cause harmful interference to radio or television reception, which can be determined by turning the equipment off and on, the user is encouraged to try to correct the interference by one or more of the following measures:

- Reorient or relocate the receiving antenna.
- Increase the separation between the equipment and receiver.
- Connect the equipment into an outlet on a circuit different from that to which the receiver is connected.
- Consult the dealer or an experienced radio/TV technician for help.

Modifications not expressly approved by the manufacturer could void the user's authority to operate the equipment under FCC rules.

SYSTEM

Genelec 7260A, 7270A and 7271A DSP subwoofers are designed for precise monitoring of 24 bit/192 kHz AES/EBU digital audio signal. They are fully compatible with Genelec Loudspeaker Manager GLM™ and the proprietary Genelec loudspeaker control network and Genelec 8240A and 8250A DSP loudspeakers.

The DSP subwoofers can perform bass management. The DSP bass management system splits the signal from each input into low and high frequency components. Signal content below the crossover frequency is reproduced by the subwoofer and signal content above the crossover frequency is reproduced by the loudspeakers connected to the outputs of the subwoofer.

USING THE 7260A, 7270A AND 7271A IN STAND-ALONE MODE

When the subwoofers are not connected to the Genelec loudspeaker control network, they operate in stand-alone mode and only the functions actuated by the controls on the connector panel can be used. However, the settings made with the Genelec Loudspeaker Manager software can be saved into each subwoofer and applied even when the network is disconnected by setting switch 1 "STORED/MANUAL CONTROL" on switch group 2 of each loudspeaker to position "STORED."

This manual concentrates on using the subwoofers without the control network. All issues concerning the control network are explained in detail in the System Operating Manual provided with the GLM™ Genelec Loudspeaker Manager kit.

INSTALLATION

Each subwoofer is supplied with a mains cable, one 5 m GLM network cable and an operating manual. Once unpacked, place the subwoofer in a suitable location (for more details see the "Positioning" section).

Before connecting the audio signal cables, ensure that both the subwoofer and the main loudspeakers are switched off. Connections are easier to make if you roll the subwoofer on its side with the connector panel facing up. Use this position only for making the connections and roll the subwoofer back to its normal upright position before use.

Connections

Audio connections

Audio connections to the subwoofer are made by XLR connectors. All audio cabling from the source must always go first to the input connectors of the subwoofer and then on to the main loudspeakers from the subwoofer's output connectors. Some typical setups are shown in "Cabling examples" below.

Connect the digital audio signal cables from your signal source to the four female XLR "AES/EBU INPUT" connectors. The inputs accept AES/EBU signal or S/P-DIF or AES3id signals with suitable impedance converters. Both Single-Wire and Dual-Wire AES/EBU formats are automatically detected and supported. The 7260A, 7270A and 7271A cannot be used with analog audio input signal. If the chosen audio format includes an LFE (.1) channel, it must be connected to INPUT 4 and the "LFE IN USE" switch must be turned to "YES" position in order to utilize the versatile LFE channel controls integrated in the subwoofer. If there is no LFE channel to reproduce, INPUT 4 can be used for a normal full-bandwidth signal. In this case the "LFE IN USE" switch must be turned to "NO"

Connect the signal cables for the main loudspeakers to the male "AES/EBU OUTPUT" connectors on the subwoofer. Each of these connectors carries a high-pass filtered version of the signal(s) received by the input connector marked with the same number. The default filtering frequency is 85 Hz. The filtering frequency cannot be changed with the controls available in the stand-alone mode. This feature is only available when the subwoofer is controlled by the GLM™ software.

Network, mains, bypass and remote connectors

Two "CONTROL NETWORK" RJ-45 sockets are provided to connect the subwoofer to the proprietary Genelec loudspeaker control network. See the System Operating Manual for more information. The mains cable may only be connected to an earthed mains power supply. The "BYPASS" 1/4" Jack provides connection to the optional Genelec 1092-400 switch to operate the Bypass function. See "DSP Subwoofer Features" for description of this function.

The “REMOTE” RJ 11 connector can be used to connect the optional Remote Power/OVL LED (Genelec 7000-415) or 7000-416 Remote control switch for "Bypass" and "+10 dB LFE" functions.

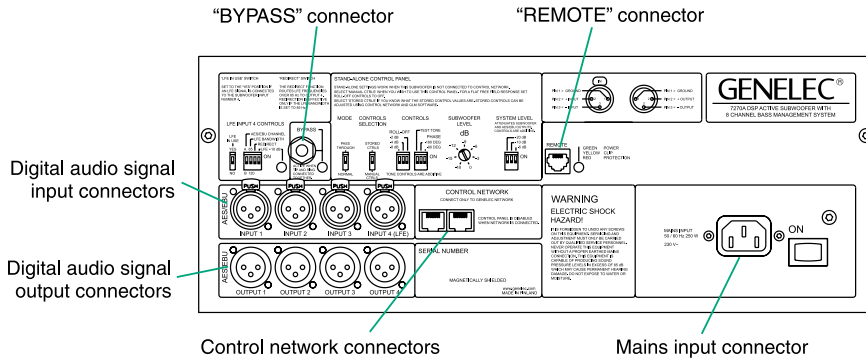

Cabling examples

Stereo Pair with Subwoofer (AES/EBU Single-Wire)

This setup has one AES/EBU cable that carries both the Left and Right audio channels with subframe A carrying the Left audio channel and subframe B carrying the Right audio channel.

Run one AES/EBU cable from the source to one of the subwoofer’s “INPUT” connectors, then from the corresponding “OUTPUT” connector to the “DIGITAL IN” connectors on the Left and Right loudspeakers (the order of cabling to the loudspeakers is irrelevant). The correct subframe must be selected in each loudspeaker.

Cable number	Subframe	Audio channel	Subwoofer Input Connector	Loudspeaker Input Connector
1	A	Left	AES/EBU INPUT 1	DIGITAL IN
1	B	Right	AES/EBU INPUT 1	DIGITAL IN

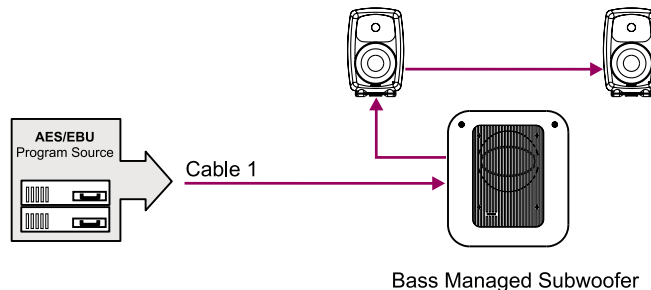

5.1 Surround System with Subwoofer (AES/EBU Single-Wire)

This setup utilizes three AES/EBU cables to carry 5.1-audio. “5.1” refers to having five full-bandwidth audio channels and an LFE channel. All three cables run to the subwoofer first, then from the subwoofer to the five main loudspeakers.

The AES/EBU digital audio cables are numbered from one to three. The AES/EBU subframe assignments and connectors to be used with the subwoofer and loudspeakers are provided in the table below.

Run three AES/EBU cables from the source to the subwoofer AES/EBU inputs 1, 2 and 4. Subwoofer input number 3 is not used. Run the cables from the subwoofer AES/EBU outputs 1, 2 and 4 to the digital audio inputs of the loudspeakers. The cable that carries the LFE channel must be connected to the subwoofer input number 4. The correct subframe must be selected in each loudspeaker.

Cable number	Subframe	Audio channel	Subwoofer Input Connector	Loudspeaker Input Connector
1	A	Left Front	AES/EBU INPUT 1	DIGITAL IN
1	B	Right Front	AES/EBU INPUT 1	DIGITAL IN
2	A	Left Rear	AES/EBU INPUT 2	DIGITAL IN
2	B	Right Rear	AES/EBU INPUT 2	DIGITAL IN
3	A	Center Front	AES/EBU INPUT 4	DIGITAL IN
3	B	LFE	AES/EBU INPUT 4	--

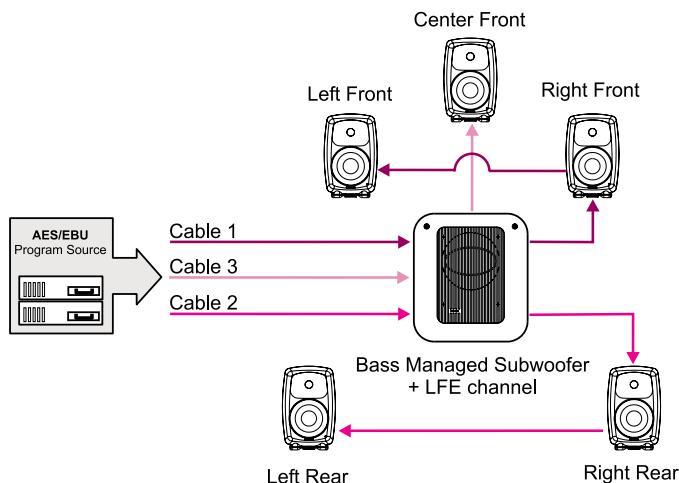

6.1 Surround System with Subwoofer (AES/EBU Single-Wire)

This setup utilizes four AES/EBU cables to carry “6.1-audio”. “6.1” refers to having six full-bandwidth audio channels and an LFE channel. All cables run to the subwoofer first, then from the subwoofer to the six loudspeakers.

The AES/EBU digital audio cables are numbered one to four. The AES/EBU subframe assignments and connectors to be used with the subwoofer and two-way loudspeakers are provided in the table below. The correct subframe must be selected in each loudspeaker.

Cable number	Subframe	Audio channel	Subwoofer Input Connector	Loudspeaker Input Connector
1	A	Left Front	AES/EBU INPUT 1	DIGITAL IN
1	B	Right Front	AES/EBU INPUT1	DIGITAL IN
2	A	Left Rear	AES/EBU INPUT 2	DIGITAL IN
2	B	Right Rear	AES/EBU INPUT 2	DIGITAL IN
3	A	Center Rear	AES/EBU INPUT 3	DIGITAL IN
3	B	Not used	Not used	--
4	A	Center Front	AES/EBU INPUT 4	DIGITAL IN
4	B	LFE	AES/EBU INPUT 4	--

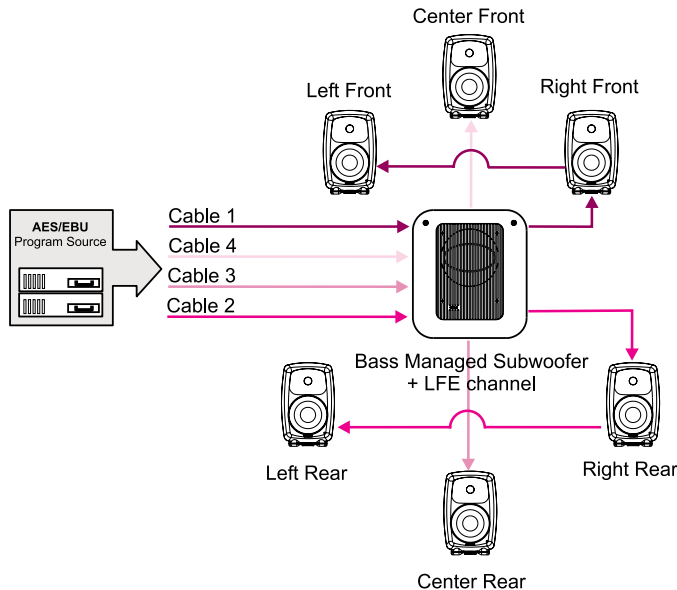

Run four AES/EBU cables from the source to the subwoofer AES/EBU inputs 1, 2, 3 and 4. Run the cables from the subwoofer AES/EBU outputs 1, 2, 3 and 4 to the digital audio inputs of the loudspeakers. The cable that carries the LFE channel must be connected to the subwoofer input number 4.

7.1 Surround System with Subwoofer (AES/EBU Single-Wire)

This setup uses four AES/EBU cables to carry “7.1-audio”. “7.1” refers to seven full-bandwidth audio channels and an LFE channel. All cables run to the subwoofer first, then from the subwoofer to the seven loudspeakers. In this system there are five loudspeakers in the front (Left Front, Center Front, Right Front, Left Front Extra, and Right Front Extra), two loudspeakers in the rear (Left Rear and Right Rear), and the LFE Low Frequency Effects channel reproduced by the subwoofer. The AES/EBU digital audio cables are numbered one to four. The AES/EBU subframe assignments and connectors to be used with the subwoofer and loudspeakers are provided in the table below. The correct subframe must be selected in each loudspeaker.

Cable number	Subframe	Audio channel	Subwoofer Input Connector	Loudspeaker Input Connector
1	A	Left Front	AES/EBU INPUT 1	DIGITAL IN
1	B	Right Front	AES/EBU INPUT 1	DIGITAL IN
2	A	Left Rear	AES/EBU INPUT 2	DIGITAL IN
2	B	Right Rear	AES/EBU INPUT 2	DIGITAL IN
3	A	Left Front Extra	AES/EBU INPUT 3	DIGITAL IN
3	B	Right Front Extra	AES/EBU INPUT 3	DIGITAL IN
4	A	Center Front	AES/EBU INPUT 4	DIGITAL IN
4	B	LFE	AES/EBU INPUT 4	--

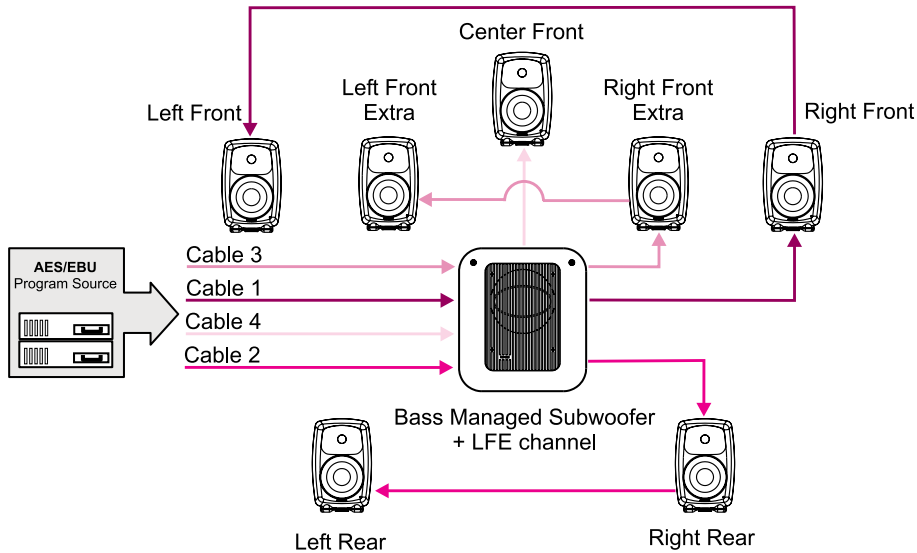

Stereo Pair with a Subwoofer (AES/EBU Dual-Wire)

This setup has two AES/EBU cables. Each carries one audio channel.

This mode assumes the source uses the Dual-wire mode of transmission. In this mode the AES/EBU interface is operating at double speed (96 kHz) but consecutive audio samples use both subframes, resulting in quad sample rate (192 kHz).

Run two AES/EBU cables from the source to the subwoofer AES/EBU Inputs 1 and 2. Run two audio cables from the subwoofer AES/EBU outputs 1 and 2 to the digital audio inputs of the left and right loudspeakers. The correct subframe must be selected in each loudspeaker.

Cable number	Subframe	Audio channel	Subwoofer Input Connector	Loudspeaker Input Connector
1	A+B	Left	AES/EBU INPUT 1	DIGITAL IN
2	A+B	Right	AES/EBU INPUT 2	DIGITAL IN

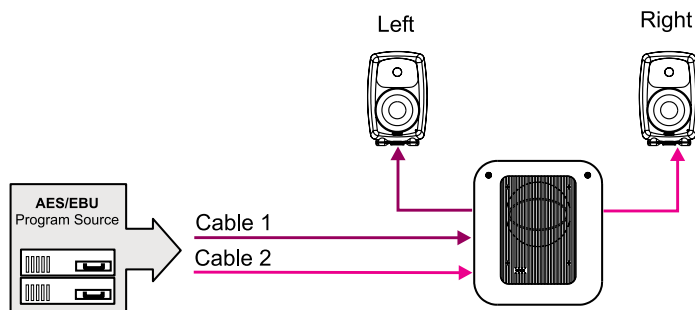

5.1 Surround System with Subwoofer (AES/EBU Dual-Wire)

This setup supports six digital audio cables. The six cables customarily carry the Left, Center and Right Front channels and the Left and Right Rear channels and the LFE. The rear channels are not bass managed.

This mode assumes the source uses the Dual-wire mode of transmission. In this mode the AES/EBU interface is operating at double speed (96 kHz) but consecutive audio samples use both subframes resulting in quad sample rate (192 kHz).

Cable number	Subframe	5.1 system audio channel	Subwoofer Input Connector	Loudspeaker Input Connector
1	A+B	Left Front	AES/EBU INPUT 1	DIGITAL IN
2	A+B	Right Front	AES/EBU INPUT 2	DIGITAL IN
3	A+B	Left Rear	--	DIGITAL IN
4	A+B	Right Rear	--	DIGITAL IN
5	A+B	Center Front	AES/EBU INPUT 3	DIGITAL IN
6	A+B	LFE	AES/EBU INPUT 4	DIGITAL IN

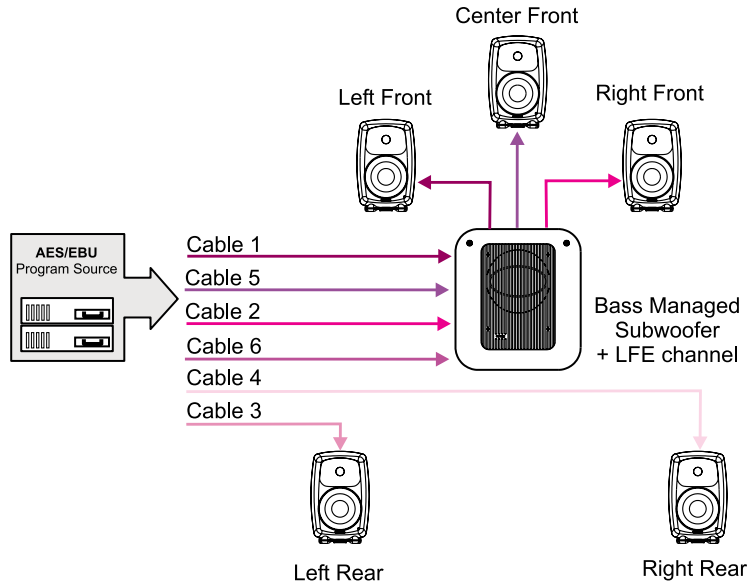

Positioning the subwoofer in the room

The placement of the subwoofer in the room affects the overall frequency response and sound level of the system dramatically, as at low frequencies the effects of the room are strong. Even a slight change in the subwoofer's location can make a marked difference in the frequency balance and often patient and methodical experimentation and testing is needed to find the optimum placement.

The placement will affect the phase difference between the main loudspeakers and the subwoofer, and also the bass roll-off rate. These effects can be compensated by the use of the Tone and Phase controls on the subwoofer; but we recommend that at first you leave the controls untouched and concentrate on finding the position where the subwoofer gives the smoothest response, and only then use them to fine-tune the balance and phase alignment between the subwoofer and the main loudspeakers.

To begin, place the subwoofer at the front wall slightly offset from the center. The recommended distance to the wall is less than 60 cm / 24" measured from the subwoofer's driver. This position gives increased acoustic loading (and SPL) due to the proximity of the front wall and floor. Cancellations from the front wall and floor are also avoided. Front wall cancellation for the 85 Hz high pass filtered main loudspeakers can be eliminated by placing them at least 110 cm / 43" away from the front wall. In a multichannel system the main loudspeakers should ideally be positioned symmetrically and at an equal distance from the listening position.

If the frequency balance is not right, try moving the subwoofer slightly to the left or right so that different room modes are excited at different levels. Positioning the subwoofer close to a corner will boost the bass level at lower frequencies and may cause asymmetrical spatial imaging. If you are using two subwoofers, try placing them asymmetrically relative to the side walls. Sometimes moving the subwoofers apart into the front corners helps with problematic rear wall reflections and the loss of mutual coupling is compensated by the bass boost caused by corner positioning.

Although the 7260A, 7270A and 7271A subwoofers are magnetically shielded, they may cause some picture distortion if placed near to very sensitive video monitors or computer displays. Move the subwoofer further away or try turning the driver side of the subwoofer away from the screen.

Minimum clearances to walls or other objects

The power amplifiers are attached to the lower part of the aluminium grille functioning as a heatsink. Do not cover the grille or place the subwoofer so that there is less than 10 centimeters (4") of free space in front of the grille. The space adjacent to the subwoofer must either be ventilated or sufficiently large to dissipate heat so that the ambient temperature does not rise above 35 degrees Celsius (95°F).

Make sure that the space underneath the subwoofer is clear from obstructions. Thick carpets may block the ventilation clearance needed for cooling the electronics box. The reflex port side (opposite of the connector panel side) should always have a clearance of at least 7,5 centimeters (3") to any objects to ensure proper functioning of the reflex port.

Flush mounting the subwoofer

If the subwoofer is flush mounted into a wall or a cabinet, it is important to ensure unrestricted airflow from the reflex port and amplifier cooling. This can be done by making the recess 7,5 centimeters (3") wider than the subwoofer. Place the subwoofer into the right end of the recess with the driver side facing the room. This leaves sufficient 7,5 centimeters (3") of free space on the reflex port side. The height and depth of the recess should not be any bigger than those needed to fit the subwoofer flush with the wall surface.

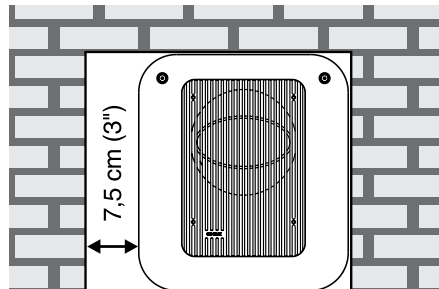

DSP SUBWOOFERS FEATURES

Various controls and switches are accessible on the DSP subwoofer control panel. Let us define and explain here their use and function (from left to right):

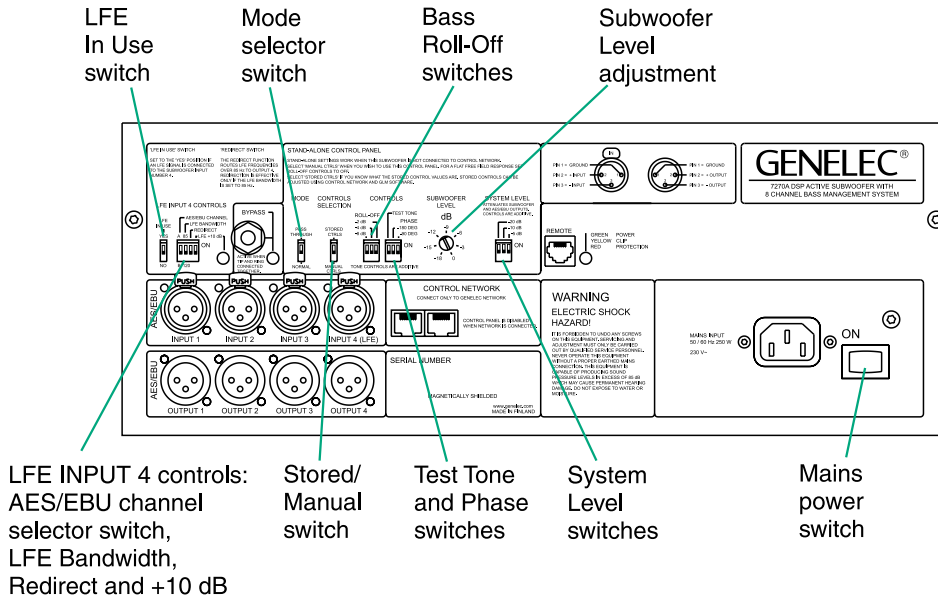

LFE INPUT 4 CONTROLS

LFE in Use

When producing audio content in multichannel audio formats, the use of the LFE channel is directly linked to the media release format and the type of production. If in use, the LFE or (.1) channel must be connected to AES/EBU INPUT 4 and the 'LFE IN USE' switch must be set to YES position. If no LFE signal is used, the 'LFE IN USE' switch should be set to NO position. The LFE input (AES/EBU INPUT 4) then operates in the same way as the other inputs.

When a dual-wire signal is connected, the input changes to dual-wire mode. In dual-wire mode there is only one channel per cable. If the LFE signal is connected to INPUT 4 and the LFE signal is a dual-wire signal, then the AES/EBU CHANNEL" setting (see below) is ignored

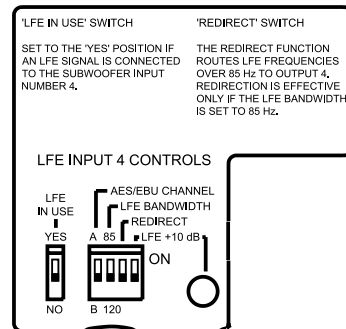

AES/EBU Channel

An AES/EBU signal normally carries two audio channels in what are called subframes A and B. The “AES/EBU CHANNEL” switch selects if the LFE signal is designated to subframe A or B.

LFE Bandwidth

The LFE input can be set to two frequency ranges: 19 to 85 Hz or 19 to 120 Hz using the “LFE BANDWIDTH” switch. Signal content in the LFE signal above the frequency value selected on the “LFE BANDWIDTH” switch is either not reproduced or is redirected (see below). See also “Typical applications of different LFE bandwidth settings” below.

Redirect

Using redirection allows the LFE channel to be monitored as a full-bandwidth audio channel. If the LFE signal includes content higher than 120 Hz, it can be monitored using the “Redirect” function. This function allows rerouting of LFE signal above 85 Hz to the front center loudspeaker. This rerouted LFE content is known as the redirected LFE signal.

Setting the “REDIRECT” switch to the “ON” position activates the redirect function and it can only be activated if the “LFE BANDWIDTH” switch is set to “85”.

The redirected LFE signal is added to the audio signal contained in the other subframe of the AES/EBU audio cable connected to INPUT 4. Typically the LFE channel is paired with the Front Center channel, so one of the subframes of OUTPUT 4 carries the sum of the redirected LFE signal and the center channel signal. OUTPUT 4 should then be connected to the Front Center loudspeaker.

Subwoofer input 4		Subwoofer output 4	
Subframe A	Subframe B	Subframe A	Subframe B
Center signal	LFE signal	Center + redirected LFE signal	
LFE signal	Center signal		Center + redirected LFE signal

LFE +10 dB

In Dolby Digital and DTS encoding formats the LFE channel is monitored with +10 dB gain relative to the main channels. The object is to increase the headroom in the recorded signals. Surround sound decoders may automatically add +10 dB of LFE gain to restore the level balance.

The “LFE +10 dB” function of the DSP subwoofers is designed to add the +10 dB of gain to the LFE channel in the production stage if it is not already done by the source connected to the monitoring system,

Switching the “LFE +10 dB” switch to the “ON” position or using the optional remote control activates the function. A yellow light next to the “LFE +10 dB” switch illuminates when the “LFE +10 dB” function is activated and +10 dB of gain is added to the LFE signal. If the audio source outputs the LFE signal at the same level as the other (non-LFE) signals and the LFE should be reproduced at a 10 dB higher level, set this control to “ON”. If the LFE output is at a 10 dB higher level than other (non-LFE) channels, this switch should be set to “OFF”.

The “LFE +10 dB” function should not be used in the following cases:

- If the +10 dB LFE gain is already implemented by another device, for example, a DVD player, surround sound processor or the output matrix of a mixing console
- When producing an audio format that does not require the use of +10 dB gain on the LFE channel, such as DVD-Audio (MLP) and SACD (DSD).

More than one subwoofer can be used to reproduce the same audio channels by connecting subwoofers in a chain using additional signal cables. This is called “daisy-chaining”. When daisy-chaining subwoofers the switches in the “LFE INPUT 4 CONTROLS” group must be the same for all the subwoofers in the daisy-chain.

Bypass

The “BYPASS” section allows the use of an optional Genelec 1092-400 remote bypass switch. This allows for remote control of the subwoofer’s bass management bypass function. The red “BYPASS” light is illuminated when the bypass mode is active.

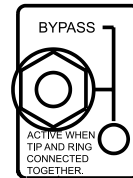

With the bypass mode on, the high pass filters for the loudspeakers are disabled and the system behaves as if the subwoofer was not connected. The bypass function has no effect on the LFE signal. If there is no LFE signal, the subwoofer will not reproduce any signal when the bypass is active.

MODE

The “MODE” switch allows joining together two or more subwoofers to reproduce the same audio channels at an increased sound pressure level. This is called daisy-chaining subwoofers.

MODE

When daisy-chaining two or more subwoofers, the audio channels are connected to the first subwoofer in the chain and the “MODE” switch is set to “PASS THROUGH”. The signals coming from the outputs of this subwoofer are not filtered, thereby allowing more subwoofers to be connected in a chain.



To build the daisy-chain, the outputs from the first subwoofer are connected to the inputs of the second

subwoofer. The outputs of the second subwoofer are connected to the inputs of the third subwoofer and so on. All “MODE” switches in the subwoofer daisy-chain are set to the “PASS THROUGH” position except the last which is set to “NORMAL”. The last subwoofer will then apply the bass management filtering for the loudspeakers connected to its outputs.

When two subwoofers are daisy-chained together in the same system, the in-room sound pressure level increases by 6 dB, three subwoofers gives an increase of 9.5 dB and four subwoofers gives an increase of 12 dB compared to a single subwoofer. To compensate for this increase in bass level, adjust “SUBWOOFER LEVEL” in all the subwoofers in the daisy-chain down to the same level to match the sound level to the loudspeaker sound level.

Controls selection

The subwoofer works in stand-alone mode when the GLM Control Network is not connected. The “CONTROLS SELECTION” switch allows selection between two basic methods to control a subwoofer in stand-alone mode.

CONTROLS SELECTION

“MANUAL CTRLS” refers to controlling the subwoofer using the controls on the subwoofer’s connector panel.



“STORED CTRLS” refers to using the settings stored inside the memory of the subwoofer. These settings can be set using the GLM Loudspeaker Manager Software and the GLM control network. The stored settings provide additional functionality compared to the basic controls on the panel.

When the GLM Control Network is connected, or when the “CONTROLS SELECTION” switch is in the “STORED CTRLS” position, some of the controls on the subwoofer’s electronics panel may be disabled (see table below). They are disabled because the subwoofer is being controlled through the GLM Control Network, or by the settings stored inside the memory of the subwoofer. If a disabled control on the panel is adjusted, all the lights on the connector panel flash rapidly to inform that the control is disabled and that the change has no effect.

Selection	Switch setting									
	LFE In Use	LFE AES/EBU Channel	LFE Bandwidth	Redirect	LFE +10 dB	Bypass	Mode	Tone Controls	Subwoofer Level	System Level
STORED	Disabled	Disabled	Disabled	Disabled	Active	Active	Disabled	Disabled	Disabled	Disabled
MANUAL CTRL	Active	Active	Active	Active	Active	Active	Active	Active	Active	Active

Roll-Off

The frequency response of the subwoofer may have to be adjusted to match the acoustic environment. The Bass Roll-Off adjustment reduces the level of the very low subwoofer frequencies. You can combine the -2 dB, -4 dB and -8 dB switches, providing an attenuation range from 0 to -14 dB – see table below for examples of combinations and the corresponding attenuation.

Roll-Off	Sw 1 (-8 dB)	Sw 2 (-4 dB)	Sw 3 (-2 dB)
-0 dB	OFF	OFF	OFF
-2 dB	OFF	OFF	ON
-4 dB	OFF	ON	OFF
-6 dB	OFF	ON	ON
-8 dB	ON	OFF	OFF
-10 dB	ON	OFF	ON
-12 dB	ON	ON	OFF
-14 dB	ON	ON	ON

Test Tone:

The DSP subwoofers contain a tone generator for phase alignment. The “TEST TONE” switch activates the tone generator at the crossover frequency. The test tone signal is sent to OUTPUT 1 on AES/EBU subframe A. To perform an adjustment one main loudspeaker has to be connected to this channel and set to reproduce this signal with the subwoofer.

Phase:

The phase relationship between a main loudspeaker and the subwoofer must be adjusted at the crossover point. A 0, -90, -180 or -270 degrees of adjustment is provided at 85 Hz – see table below for switches combinations and the corresponding phase change. Incorrect phase alignment between the loudspeakers and the subwoofer causes a drop in the frequency response around the crossover frequency.

Acoustic measuring equipment such as Genelec AutoCal accurately align the phase. Alternatively, the following quick phase alignment process can be done:

Phase	Sw 6 (-180 deg)	Sw 7 (-90 deg)
0°	OFF	OFF
-90°	OFF	ON
-180°	ON	OFF
-270°	ON	ON

- Disconnect all loudspeakers from the subwoofer outputs.
- Select the loudspeaker to be used as the reference for the phase alignment. Typically, this is the Front Center loudspeaker in a 5.1 multi-channel system.
- Connect this loudspeaker to subwoofer's AES/EBU OUTPUT 1 connector.
- Select subframe A for reproduction on the reference loudspeaker.
- The test tone is played simultaneously from the subwoofer and loudspeaker.
- Listen to the tone and adjust both "PHASE" control switches to find the setting that gives the minimum tone level at the listening position.
- After having found this minimum level setting, set the "-180 DEG" switch to the opposite setting to complete the setup. This puts the subwoofer in phase with the reference loudspeaker and completes the phase calibration.
- Finally, reconnect all loudspeakers to the subwoofer outputs.

In a system with multiple daisy-chained subwoofers, the Phase and Bass Roll-Off adjustments should be performed individually for each subwoofer in the system.

- Set the "MODE" switch on all subwoofers to the "NORMAL" position and disconnect the cables from the outputs of all the subwoofers.
- Follow the phase alignment process detailed above by connecting the reference loudspeaker to each subwoofer in turn and adjust the "PHASE" control switches.
- Finally, set the "MODE" switches on all subwoofers to a setting appropriate for their position in the daisy-chain - all subwoofers set to "PASS THROUGH" mode except the last which is set to "NORMAL".

Subwoofer level

The level of the subwoofer relative to the loudspeakers can be adjusted with the "SUBWOOFER LEVEL" rotary control. This control allows matching the subwoofer level to the levels of the other loudspeakers.

When two subwoofers are daisy-chained together in the same system, the in-room sound pressure level increases by 6 dB, three subwoofers gives an increase of 9.5 dB and four subwoofers gives an increase of 12 dB compared to a single subwoofer. To compensate for this increase in bass level, adjust "SUBWOOFER LEVEL" in all the subwoofers in the daisy-chain to the same level to match the sound level to the loudspeaker sound level.

System level

All digital audio inputs and outputs are referenced to 0 dBFS (digital Full Scale, the largest possible signal that can be represented by an AES/EBU signal). Genelec DSP loudspeakers produce a sound pressure level of 100 dB (at one meter distance in free space) for a digital input signal of -30 dBFS.

If the digital source can control the digital level, it may be advantageous to lower the sensitivity either with the GLM or the "SYSTEM LEVEL" control of the DSP subwoofer. This will enable the use of the upper end of the digital level controller.

The "SYSTEM LEVEL" switch group allows scaling the maximum sound level of the whole loudspeaker system. This control changes the subwoofer level as well as the levels of all loudspeakers connected to the subwoofer outputs.

It may be necessary to use the "SYSTEM LEVEL" attenuation switches to ensure that high-level digital audio signals do not overload the loudspeaker system. The suitable setting also depends on the listening distance. The correct setting for this control depends on the program source and the maximum sound level needed.

Note that when daisy-chaining subwoofers, the "SYSTEM LEVEL" controls in all subwoofers in the daisy-chain must be set to the same setting. For example, if the "SYSTEM LEVEL" control is set to -10 dB, this should be set on all subwoofers in the daisy-chain.

Connector panel warning light

Normally the light on the connector panel of an 7200 subwoofer is green, indicating that the subwoofer is in normal operational mode.

If the output capacity of the power amplifier is exceeded (clipping in the power amplifier), the light turns yellow. Red colour indicates thermal overload of the power amplifier or loudspeaker drivers (thermal protection has activated). In each of these cases, turn the source level down.

Bit errors in the AES/EBU digital audio data or exceeding the maximum input range of the digital output cause audible distortion, but are not indicated by the warning light.

Typical applications of different LFE bandwidth settings

Using the 85 Hz LFE bandwidth setting with "Redirect" function is the most universal configuration for LFE monitoring. However, there are situations when the band-limited LFE settings serve a definite purpose.

Limiting the LFE bandwidth to 85 Hz without using the "Redirect" function can be used to simulate the effect of some consumer decoders that do not replay information above 80 Hz on the LFE channel when

the bass management is used. Checking the multichannel mix with this setting on lets you know how it translates in systems with this limitation.

The 120 Hz LFE bandwidth setting complies with the replay systems of movie theaters and cinemas. 35 mm movie soundtracks use the LFE channel to reproduce a bandwidth of 20 - 120 Hz through dedicated subwoofers. In this case the LFE and main channel bandwidths overlap between 85 and 120 Hz, which may create unwanted acoustical summing if the same signal is present in both channels. To avoid this, the LFE content should be kept completely different (de-correlated) from the low frequency content of the main channels when mixing music and sound effects for film release.

Maintenance

No user serviceable parts are to be found within the subwoofer enclosure. Any maintenance or repair of the loudspeaker should be undertaken by qualified service personnel only.

Safety considerations

Although the 7260A, 7270A and 7271A have been designed in accordance with international safety standards, to ensure safe operation and to maintain the subwoofer under safe operating conditions, the following warnings and cautions must be observed:

1. Servicing and adjustment may only be performed by qualified service personnel. The subwoofer enclosure must not be opened.
2. Do not use this product with an unearthed mains cable or a mains connection without the protective earth contact as this may lead to personal injury
3. To prevent fire or electric shock, do not expose the unit to water or moisture. Do not place any objects filled with liquid, such as vases on the subwoofer or near it.
4. Note that the amplifier is not completely disconnected from the AC mains service unless the mains power cord is removed from the subwoofer or the mains outlet.
5. Free flow of air around the subwoofer is necessary to maintain sufficient cooling. Do not obstruct airflow around the subwoofer.

WARNING!

Genelec 7260A, 7270A and 7271A subwoofers are capable of producing sound pressure levels in excess of 85 dB, which may cause permanent hearing damage.

Guarantee

Genelec 7260A, 7270A and 7271A subwoofers are supplied with one year guarantee against manufacturing faults or defects that might alter the performance of the subwoofer. Refer to supplier for full sales and guarantee terms.

	7260A	7270A	7271A
Free field frequency response (± 3.0 dB)	19 Hz - 100 Hz		
Maximum short term sine wave SPL output averaged from 30 to 85 Hz, measured in half space at 1 meter	≥ 108 dB SPL	≥ 112 dB SPL	≥ 118 dB SPL
Maximum peak SPL output with random pink noise, measured in half space @ 1 meter	≥ 113 dB SPL	≥ 117 dB SPL	≥ 123 dB SPL
Self generated noise level in free field @ 1 m (A-weighted)	≤ 15 dB		
Harmonic distortion @ 1 m in half space 30 to 85 Hz	@ 90 dB SPL	@ 95 dB SPL	@ 100 dB SPL
2nd	≤ 3 %	≤ 3 %	≤ 3 %
3rd	≤ 2 %	≤ 3 %	≤ 3 %
Driver, magnetically shielded:	250 mm (10")	305 mm (12")	2 x 305 mm (12")
Weight:	27 kg (58 lbs)	51 kg (111 lbs)	82 kg (179 lbs)
Dimensions:			
Height	527 mm (20 3/4")	625 mm (24 5/8")	755 mm (29 3/4")
Width	462 mm (18 3/16")	555 mm (21 7/8")	803 mm (31 5/8")
Depth	363 mm (14 5/16")	490 mm (19 5/16")	490 mm (19 5/16")
	7260A	7270A	7271A
Short term amplifier output power (Long term output power is limited by driver unit protection circuitry)	120 W	250 W	500 W
Amplifier system distortion at nominal output THD	≤ 0.05 %	≤ 0.05 %	≤ 0.05 %
Mains voltage	100, 120, 220 or 230 V according to region		
Voltage operating range	± 10 %	± 10 %	± 10 %
Power consumption			
Idle	15 VA	15 VA	30 VA
Full output	150 VA	250 VA	500 VA
	7260A	7270A	7271A
Subsonic filter (18 dB/octave) below	19 Hz		
Crossover frequency, (sub/main channels)	85 Hz default in stand-alone use		
LFE cutoff Hz	85 Hz/120 Hz selectable		
Bass Roll-Off control operating range in 2 dB steps @ 20 Hz	From 0 to -14 dB		
Phase matching control in 90° steps	From 0 to -270°		
Subwoofer Level control	0 to -18 dB		
System Level control	0 to -35 dB in 5 dB steps		

	7260A	7270A	7271A
Digital audio input connectors	4 XLR female		
Digital audio input impedance	110 Ohm		
Digital audio output connectors	4 XLR male		
Digital audio output impedance	110 Ohm		
Digital audio format	AES/EBU (AES3-2003) Can also be used with S/P-DIF and AES3id signals when impedance converters are used		
Digital audio word length	16 bits, maximum 24 bits. Fixed point, AES/EBU format		
Digital audio sample rate	32 kHz, maximum 192 kHz Supports single-wire and dual-wire AES signals.		

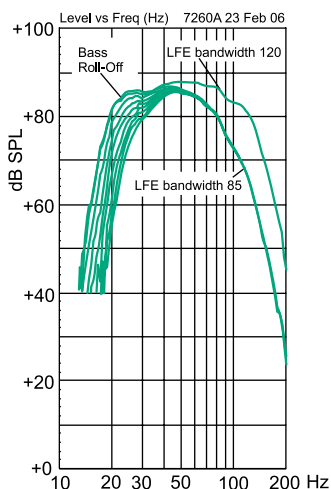

The free field frequency response of the 7260A subwoofer at different Bass Roll-Off settings

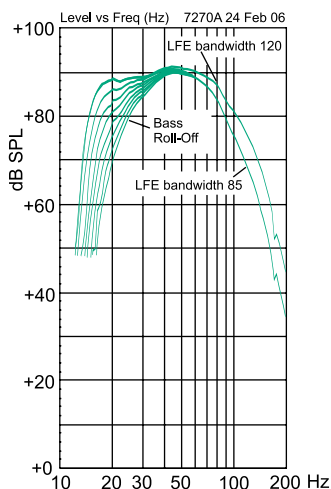

The free field frequency response of 7270A and 7271A subwoofers at different Bass Roll-Off settings.

