

# MiPRO

## ACT-707TM Wireless Microphone

### Instruction Manual



**interstage**

Phistersvej 31, 2900 Hellerup, Danmark  
Telefon 3946 0000, fax 3946 0040  
[www.interstage.dk](http://www.interstage.dk)



- pro audio with a smile

# Bodypack Transmitter

Finely crafted and ergonomically designed ACT-707TM adapts magnesium alloy housing, LCD panel, and high-efficient transmitting circuit design with low spurious showcases MIPRO's professional style.

## 1. PARTS NAME AND FUNCTIONS

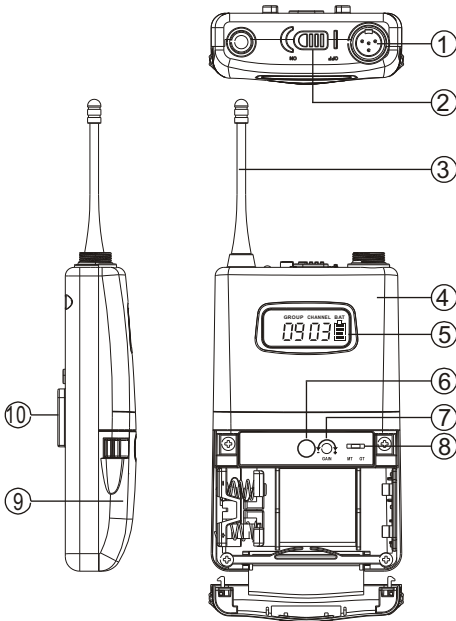

(Fig.1)

1. AF Input Jack: Connects to either a lavalier or a headset microphone. (See 5 ways of connection on AF Input Connections)
2. Power Switch: Switch to ON position for operation. Switch to OFF position when not in use.

## Bodypack Transmitter

---

3. Transmitting Antenna:  $1/4 \lambda$  transmitting antenna.
4. Transmitter Housing: Packages the PCB and battery.
5. Multi-Function LCD Display
6. ACT Signal Receptor: Receiving ACT signal and adjusting frequency automatically.
7. Gain Control: Adjusts the desirous input gain.
8. GT/MT Level Selector: Switch to GT position when under usage of electric guitar or any "Line In" audio. When connects to a condenser microphone or a wired microphone, switch to MT position and the gain control can serve as input sensitivity adjustor.
9. Battery Compartment and Cover: Accommodates two 1.5V(AA) batteries.
10. Detachable Belt Clip: Allows 360 degrees rotating to suit transmitting angles. To detach simply use a screwdriver at a 45 degree angle to unfasten. see diagram below.

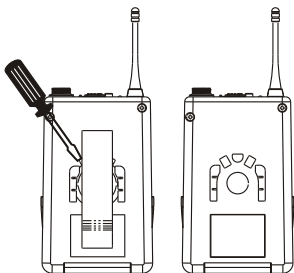

## 2. OPERATING INSTRUCTIONS

1. To adjust GT/MT Switch (9), and Gain Control (7), simply push down both snap locks on the sides of battery cover and flip it backwards to expose the adjustment panel.
2. The LED indicator flashes briefly when power on indicating normal battery status. If no flash occurs it has either no battery, the battery is drained or installed incorrectly. Change accordingly.
3. Plug the microphone connector into the input jack and tighten the connector screw **on** clockwise direction as shown in (Fig. 2).

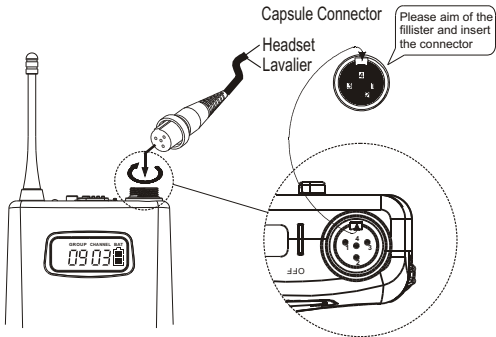

(Fig.2)

## Bodypack Transmitter

---

### FURNISHED ACCESSORIES:

- ① AA TYPE BATTERY×2
- ② CARRYING STORAGE BAG×1
- ③ INSTRUCTION MANUAL × 1

### SPECIFICATION:

ITEM	SPECIFICATIONS
ACT Function	Yes
RF Output Power	10mW (or according to regulations)
Oscillation Mode	PLL Synthesizer
Spurious Emissions	<-55dBc
Maximum Input Level	0dBV
Microphone Capsule	Condenser
Battery	AA TYPE × 2
Weight (g)	145gs
Dimensions (m/m)	105×66×25

## 3. AF INPUT CONNECTIONS

- (1) 2-Wire Electret condenser microphone Capsule

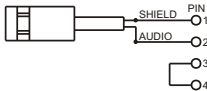

- (2) 3-Wire Electret condenser microphone Capsule

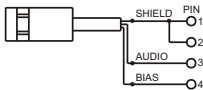

- (3) Dynamic Microphone

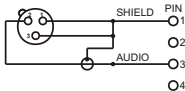

- (4) Electric Guitar

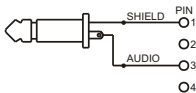

- (5) Line-in (Impedance  $8K\Omega$  ATT. 10dB)

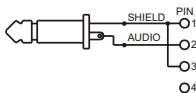

### 4. FUNCTIONS OF LCD DISPLAY



1. ERR Message: When "ERR" appears, it means "Operation Error". Please refer to the following codes to diagnose which error you are experiencing.  
  
ERR no01→EEPROM is not being programmed or internal data error.  
  
ERR no02→For testing only.  
  
ERR no03→The frequency you are about to program into the system exceeds microphone's upper limit. (At this time, microphone is still operatable and the frequency remains unchanged. To clear the "ERR" message in LCD display, simply turn off the power and switch back on.)  
  
ERR no04→The frequency you are about to program into the system is below microphone's frequency lower limit. (At this time, microphone is still operatable and the frequency remains unchanged. To clear the "ERR" message in LCD display, simply turn off the power and switch back on.)
2. "Group" & "Channel " : When both items are shown, they indicate that the user is currently using the pre-programmed frequency in the receiver.
3. "Channel" Only : If "Channel" is the only item shown in the display, it indicates the user is using the personalized frequency. (Such frequency can only be programmed via MIPRO's ACT Software and available on ACT-707MC only.)

### 4. Battery Status:

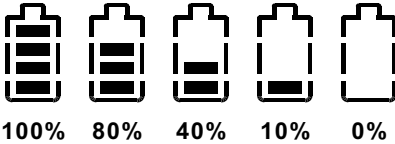

Battery Status: When the battery has less than 10% power remaining, batteries must be replaced. If undervoltage continues, LCD will show "PoFF" and shut down the system to avoid battery being over-discharged.

### 5. Switch Off:

When switch the power knob to "Off" position, LCD will show "PoFF" first. Then, the system is completely shut down and no further message will be displayed.



# Bodypack Transmitter

## 5. BATTERY INSTALLATION

1. Pushing down both snap locks on the sides of battery cover to open battery cover. Take out the batteries. Fig.(3).
2. Insert two 1.5(AA) batteries into the battery compartment according to the correct polarity as shown in Fig. (4). Then push up to close the battery compartment as shown in Fig. (4).

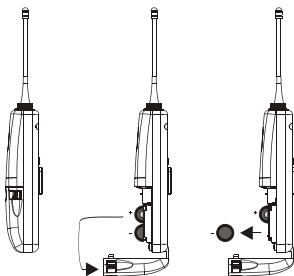

(Fig.3)

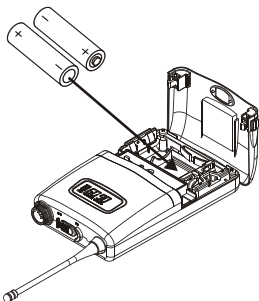

(Fig.4)

PS: When the microphone is not in use:  
Make sure the power of the microphone is off. If the microphone will not be used for some time, please remove the batteries from the battery compartment to avoid battery leakage and result in damaged battery springs and circuit. If a rechargeable battery was used, take it out and recharge it.

# MIPRO Electronics Co., Ltd.

Head office: 814, Pei-Kang Road, Chiayi, 600, Taiwan.

Taipei office: 5, Lane 118, Sung-teh Road, 110, Taipei, Taiwan.

Web-http: //www.mipro.com.tw

E-mail: mipro@mipro.com.tw

**interstage**

Phistersvej 31, 2900 Hellerup, Danmark

Telefon 3946 0000, fax 3946 0040

[www.interstage.dk](http://www.interstage.dk)

- pro audio with a smile



2CE160

FC CE0197!