

**OPERATING AND MAINTENANCE
INSTRUCTION MANUAL**

MODEL 520

**AM BROADCAST
MODULATION MONITOR**



—— USER'S RECORD ——
Model 520 – Serial No. _____
Date Purchased _____
Warranty Card Mailed — <input type="checkbox"/>

**OPERATING AND MAINTENANCE
INSTRUCTION MANUAL**

MODEL 520

**AM BROADCAST
MODULATION MONITOR**

September, 1999



1305 Fair Avenue • Santa Cruz, CA 95060
TEL: (831) 458-0552 • FAX: (831) 458-0554
Visit our Website: www.inovon.com

TABLE OF CONTENTS

Section I - INTRODUCTION

Model 520 Product Description	3
General - Features	
Model 520 Technical Specifications	4
Block Diagram	5

Section II - INSTALLATION

Unpacking and Inspection	7
Mounting	7
Rack Requirement - Heat Dissipation	
AC (Mains) Power	7
As Delivered - Voltage Selector - Power Cord	
Radio Frequency Interference (RFI)	8
Location - Ground Loops - Interference to Reception	
Antennas and the Antenna Input	9
Input Characteristic - 'Random Wire' Antennas - The Optional Active Antenna From Inovonics	
Tuning the Model 520	10
Direct (High-Level) RF Samples	10
Level Adjustment - Daytime/Night Operation	
Program Audio Output	11
De-Emphasis Jumpering	
Remote Alarms	11
Serial Interface	12

Section III - SETUP AND OPERATION

Operational Overview and Panel Appointments	13
Modulation Display - Adjustable Peak Flashers - Alarms - Headphone Jack	
Using the Model 520 Mod-Monitor	15
Co-Channel and Adjacent-Channel Interference - Impulse Noise - Interference Solutions - Manual RF Gain Control	
Remote Control of the Model 520	16
Computer and Modem Compatibility - Interconnection	

Section IV - CIRCUIT DESCRIPTIONS

Calibration Disclaimer	19
Circuit Navigation	19
'Front End'	20
Phantom Power - Manual RF Gain Control - Cascode RF Amplifier - Local Oscillator - Tuning Synthesizer - (Front- End Tuning Notes)	
Mixer and IF	21
(IF Tuning Notes)	
AM Detector and AGC	22
HIGH LEVEL Input - Phase Inverter - Detector - (Detector Adjustment Notes) - Carrier Level Recovery - Program Audio Recovery - AGC Amplifier	
Peak Integration and Hold	23
(Peak Adjustment Notes)	
Bargraph Display and Miscellaneous Functions	24
Bargraph Display - Alarms - Serial Data Interface - Power Supply	
Optional Active Antenna	25

Section VI - APPENDIX

Mod-Monitor Tuning Charts	28
Parts Lists	30
Explanation of Parts Listing - Parts Listing - Mail-Order Component Suppliers	
Schematics	33
Warranty	(Inside Back Cover)

Section I

INTRODUCTION

MODEL 520 PRODUCT DESCRIPTION

General Inovonics' 520 is a Modulation Monitor for medium-wave, AM broadcast service. It allows the broadcaster to measure and to monitor the performance of his AM transmitter and, to a significant extent, to include performance of the antenna and antenna phasing and tuning circuits in the measurements as well.

The 520 incorporates a built-in, tunable 'preselector' for accurate off-air readings. Off-air monitoring is an effective means of measuring overall transmission system performance, and may be the only option when the radio studio is located away from an unattended transmitter site. Alternatively, the 520 will accept a direct-RF sample from the transmitter, though factors such as antenna system bandwidth will not be reflected in these readings. A built-in RS-232 port does offer a second means of obtaining modulation data from a remote transmitter site

Features Salient features of the Inovonics 520 include:

- Built-in, tunable preselector for off-air, 'overall system' measurements.
- Accurate, easy-to read bargraph modulation readout with floating peak-hold indication.
- Balanced audio output with NRSC de-emphasis.
- Two sets of peak flashers: user-definable and absolute limits.
- Carrier-loss, audio-loss and modulation-limit alarms with provision for remote readout.
- Built-in RS232 interface for remote modulation display via modem, or for detailed modulation analysis by computer.
- Weatherproof ferrite-rod active antenna optionally available for challenging reception conditions.

MODEL 520 TECHNICAL SPECIFICATIONS

Tuning Range:

530kHz to 1710kHz in 1kHz increments. The receive frequency is programmed with a DIP switch under the top cover.

Modulation Display:

The front-panel bargraph readout is quasi-peak-responding with an extended persistence of the most-recent-peak 'floating' above the current reading. The display may be switched between negative and positive carrier modulation and indicates peaks from 22% to 130% in 2% increments. The display also may be switched to show the relative level of incoming carrier.

Peak Flashers:

- a) 'Absolute-limit' flashers are factory-calibrated at -100% and +125% carrier modulation.
- b) A second set of 'user defined' flashers may be set at values ranging from 80% to 130%.

Accuracy and Calibration:

Modulation readings reference the incoming unmodulated carrier level, obviating the need for an internal calibration source. RF gain for off-air measurements is servo-stabilized, and a relative measurement of the RF input level may be monitored on the front-panel bargraph readout.

RF Inputs:

- a) The 75-ohm antenna input (F connector) is phantom-powered for the optional active antenna available from Inovonics. A random wire antenna may prove adequate in high-signal areas that suffer minimal interference.
- b) A high-level input (BNC connector) accepts a direct RF sample in the 1V to 10V r.m.s. level range. This is an untuned

input for high-level samples between 300kHz and 2MHz.

Measurement Bandwidth:

Carrier amplitude demodulation extends to 10kHz, ± 0.25 dB.

Audio Response:

± 0.25 dB, 20Hz to 10kHz from a direct-RF sample; down not more than 1dB at 10kHz off-air. The audio program feed conforms to the NRSC de-emphasis characteristic, though this may be defeated for outboard measurements requiring 'flat' demodulation.

Audio Distortion:

Less than 0.5% THD at 100% carrier modulation.

Audio Noise:

Better than 55dB below 100% modulation with NRSC de-emphasis.

Program Audio Outputs:

- a) Active-balanced program audio output (XLR connector) on rear panel delivers +4dBm from a 200-ohm resistive source.
- b) Front-panel headphone jack.

Alarms:

Open-collector NPN transistor outputs for carrier loss, program audio loss, -100% modulation and +125% modulation.

Data Output:

An RS-232 serial data port (DB-9 connector) supplies raw modulation information for remote analysis or archiving.

Power Requirements:

105-130VAC or 210-255VAC, 50/60Hz; 10 watts.

Size and Weight:

1 $\frac{3}{4}$ "H x 19"W x 7"D (1U);
7 lbs. (shipping).

BLOCK DIAGRAM

A simplified Block Diagram of the Model 520 is shown in Figure 1, below. Mod-Monitor circuitry is detailed in the Circuit Descriptions section beginning on Page 19. These descriptions refer to Schematic Diagrams found in the Appendix.

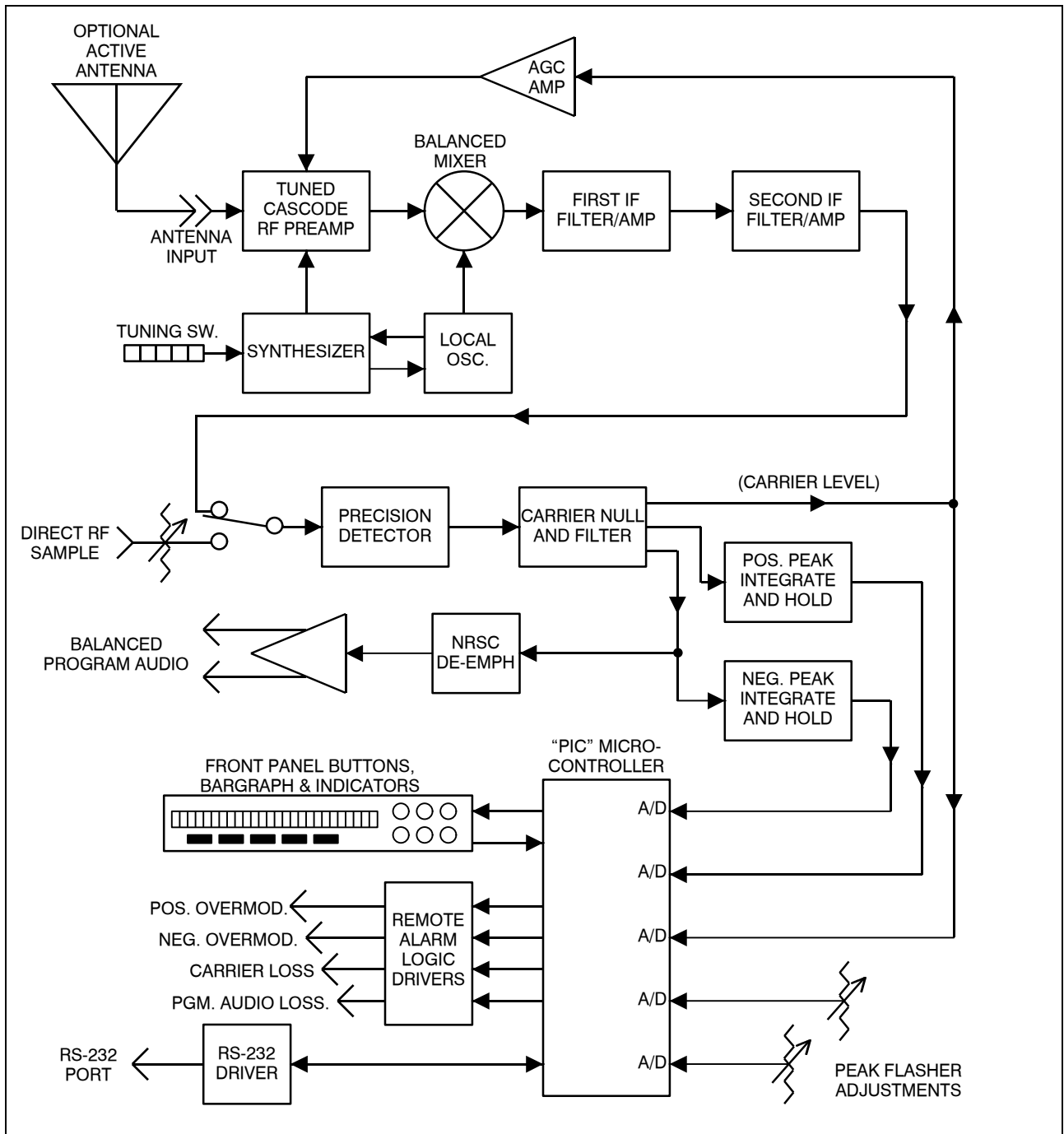

Figure 1 - Block Diagram, Model 520 AM Broadcast Modulation Monitor

Section II

INSTALLATION

UNPACKING AND INSPECTION

Immediately upon receipt of the equipment, inspect carefully for any shipping damage. If damage is suspected, notify the carrier at once, then contact Inovonics.

We recommend that you retain the original shipping carton and packing materials for return or reshipment, if necessary. In the event of return for Warranty repair, shipping damage sustained as a result of improper packing for return *may invalidate the Warranty!*

IT IS VERY IMPORTANT that the Warranty Registration Card found at the front of this Manual be completed and returned. Not only does this assure coverage of the equipment under terms of the Warranty, and provide some means of trace in the case of lost or stolen gear, but the user will automatically receive specific **SERVICE OR MODIFICATION INSTRUCTIONS** should they be issued by Inovonics.

MOUNTING

Rack Requirement

The Model 520 mounts in a standard 19-inch equipment rack and requires only 1¾ inches (1U) of vertical rack space. Plastic ‘finishing’ washers are recommended to protect the painted finish around the mounting holes.

Heat Dissipation

Consuming less power than a consumer VCR turned ‘off,’ the 520 itself generates negligible heat. The unit is specified for operation within an ambient temperature range extending from freezing to 120°F/50°C. But because adjacent, less efficient equipment may radiate substantial heat, be sure that the equipment rack is adequately ventilated to keep its internal temperature below the specified maximum ambient.

AC (MAINS) POWER

As delivered

Unless specifically ordered for export shipment, the Model 520 is set at the factory for operation from 115V, 50/60Hz AC mains. The rear-panel designation next to the fuseholder will confirm both the mains voltage selected and the value of a proper fuse.

Voltage Selector A mains voltage selector switch is located beneath the top cover of the 520, close to the AC mains connector on the circuit board. *With primary AC power disconnected*, slide the red actuator with a small screwdriver so that the proper mains voltage designation (115 or 230) shows. Be certain always to install the appropriate fuse, and check that the rear-panel voltage/fuse designation is properly marked. It is factory practice to cross-out the *inappropriate* designation with an indelible black marking pen. You can remove this strikethrough with lacquer thinner when redesignating.

BE SURE that the mains voltage selector setting and primary fuse value are appropriate for the mains supply before plugging the 520 Processor into the wall outlet.

Power Cord The detachable IEC-type power cord supplied with the Monitor is fitted with a North-American-standard male plug. Nonetheless, the individual cord conductors are *supposed* to be color-coded in accordance with CEE standards; that is:

BROWN = AC "HOT" BLUE = AC NEUTRAL
GRN/YEL = EARTH GROUND

If this turns out *not* to be the case, we offer our apologies (cords come from many sources) and advise that US color coding applies:

BLACK = AC "HOT" WHITE = AC NEUTRAL
GREEN = EARTH GROUND

RADIO FREQUENCY INTERFERENCE (R F I)

Location Although it is natural for the 520 to be installed adjacent to high-power AM transmitters, please practice care and common sense in locating the unit away from *abnormally* high RF fields.

Ground Loops Because the inputs and the outputs of the Model 520 are chassis-ground-referenced, a mains frequency or RF ground loop could be formed between the input or output cable shield grounds and the AC power cord ground. A 'ground-lifting' AC adapter may well remedy such a situation, though the chassis somehow must be returned to earth ground for safety. Generally, being screwed-down in the equipment rack will satisfy the safety requirement.

Interference to Reception The topic of co-channel and adjacent-channel interference and impulse and power-line-related noise are addressed in Section III, Page 15.

ANTENNAS AND THE ANTENNA INPUT

With its built-in preselector, the 520 is capable of very accurate off-air modulation measurements. The unit also may be used with a high-level RF sample directly from the transmitter. A toggle switch located between the two rear-panel input connectors selects the input source. For the antenna input the switch is set to the left.

Input Characteristic

The ANTENNA F connector input has an impedance of 75 ohms to match the active ferrite-rod outdoor antenna optionally available from Inovonics. Phantom powering for the Inovonics antenna is present on the connector. This simply may be ignored when using a random length of wire for local off-air pickup. Although the phantom powering is current-limited, try to avoid any antenna configuration that has a DC current path to ground.

'Random Wire' Antennas

Clearly, the 75-ohm input characteristic of the 520 does not begin to match the impedance of a random length of insulated wire draped over a doorknob. Obtaining sufficient RF energy from an electrically-short antenna demands a high-signal environment and an electrical noise level considerably below that of the targeted signal if accurate readings are to be expected.

Fortunately, there is usually more than enough stray energy at the carrier frequency from a co-located transmitter. In fact, stray RF poses more of a problem in keeping radiated power *out* of telephone systems and soft-drink vending machines, and from interfering with experiments in the paranormal.

Calling to mind the caution of grounding-out the phantom powering (or simply inserting a $0.01\mu\text{F}$ coupling capacitor in series with the antenna connection), begin with a 3-foot piece of insulated hookup wire taped to the wall, away from power cords and other possible sources of noise. Use the front-panel RF (level) display function (Page 13) to make sure there is enough signal to maintain the bargraph in the RF LEVEL RANGE window. Lengthen the antenna wire if necessary and aurally monitor for signal quality as described in the discussion on interference, Page 15.

The Optional Active Antenna From Inovonics

Inovonics' active ferrite-rod antenna was developed for use with the Model 520 in split studio/transmitter installations, or whenever a directional rooftop antenna is deemed necessary. Housed in an attractive L-shaped section of white PVC water pipe, the antenna is completely weatherproof and may be clamped to an existing mast or roof vent.

The antenna incorporates an internal preamplifier that is powered by the Model 520. The antenna's broadband design does not require tuning to the carrier frequency. Sporting an F connector identical to the Mod-Monitor's ANTENNA input, interconnection is a simple matter of using easily-obtained 75-ohm cable-TV coax already fitted with F connectors on both ends. As much as 200 feet of 75-ohm coax may be used with relative impunity.

TUNING THE MODEL 520

Off-air operation necessitates tuning the 520 Mod-Monitor to the incoming carrier frequency. This is accomplished by programming a 12-station DIP switch beneath the top cover. The entire medium-wave broadcast band (530kHz to 1710kHz) is covered in 1kHz steps, accommodating strange European 9kHz channel assignments as easily as more sensible 10kHz western hemisphere spacings.

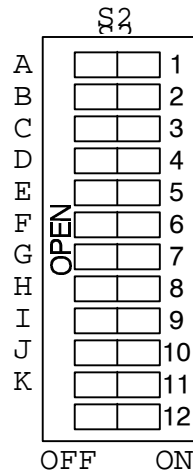

DIP switch positions are identified A through K in the circuit board artwork. (The bottommost 12th position is not used.) Pushed to the left, the switch is OFF, or logical '0' (zero). Snapped to the right (toward the synthesizer chip, IC12), the switch is ON, or logic '1' (one).

A tuning chart is affixed to the underside of the 520 top cover and also appears in the Appendix to this Manual on Pages 28 and 29. Locate the carrier frequency on the chart, then set switch sections A through K either to ON or to OFF, corresponding to the logical 1 or 0, respectively, shown on the chart for that frequency listing.

DIRECT (HIGH-LEVEL) RF SAMPLES

With the rear-panel toggle switch set to the right, the 'BNC' connector labeled HIGH LEVEL accepts an RF sample on the order of 1 to 10 volts r.m.s. This sample may be taken directly from the transmitter or from an associated tuning unit. This is a wideband input directly to the detector. The 520 *does not need to be tuned* to the incoming carrier frequency when the HIGH LEVEL input is used.

Level Adjustment

Once the 520 is installed and the direct-RF sample connected, cycle the front-panel SELECT button to read RF level. Locate the 15-turn recessed HIGH LEVEL INPUT ADJUST trimmer next to the BNC connector and set it for a 0dB, 100% reading.

The transmitter must have sufficient long-term stability to maintain the bargraph display in the RF LEVEL RANGE 'window' throughout the broadcast day. Should the transmitter power drift outside his window, the Monitor will give a CARRIER ALARM. There is no automatic control (AGC) over the HIGH LEVEL input.

Over the course of daily operation, make note of any transmitter power level drift. If the overall drift is consistent and on the order of 10% or less, readjust the HIGH LEVEL INPUT ADJUST trimmer to center this anticipated operating power range within the RF LEVEL RANGE window.

Daytime/Night Operation

The 520 does not provide for transmitter power level changeovers. We recommend an outboard attenuator arranged automatically to

reduce the RF sample feed when the transmitter changes to its higher power level.

PROGRAM AUDIO OUTPUT

An XLR male connector on the rear panel of the Model 520 gives an electronically-balanced output of recovered-audio. This may be used for program monitoring or external measurements. The level is approximately +4dBm (terminated in 600 ohms) at 100% modulation. As shipped, the demodulated audio follows the NRSC de-emphasis curve. This is a mirror-image of the FCC-mandated transmission pre-emphasis characteristic. If an output with a flat frequency characteristic is desired, the unit may be re-jumpered as described below.

De-Emphasis Jumpering

Remove the 520 top cover and locate jumper strip JMP1. This is almost dead center on the circuit board between IC8 and IC9. The push-on jumper will be installed toward the right-hand end of the strip, adjacent to the DE-E marking on the circuit board. Simply pull the jumper off and relocate it to the left, next to the FLAT designation. Keep in mind that the front-panel PHONES jack will reflect the same response characteristic as the balanced PROGRAM AUDIO output. We recommend retaining the de-emphasized output except when special measurements need to be made.

REMOTE ALARMS

Wire connections to the rear-panel barrier strip enable out-of-limits alarms to be displayed at the studio console or other remote point. These outputs are open-collector NPN transistors that saturate to ground. This requires a 'wall wart' or similar outboard DC supply to light LEDs or sound audible warning device. The two ground terminals are for DC return. Note that the entire barrier strip unplugs from the chassis to make connection easier. Figure 2, below, shows an example of LED modulation indicators and a common audible warning for loss of carrier and for loss of program audio.

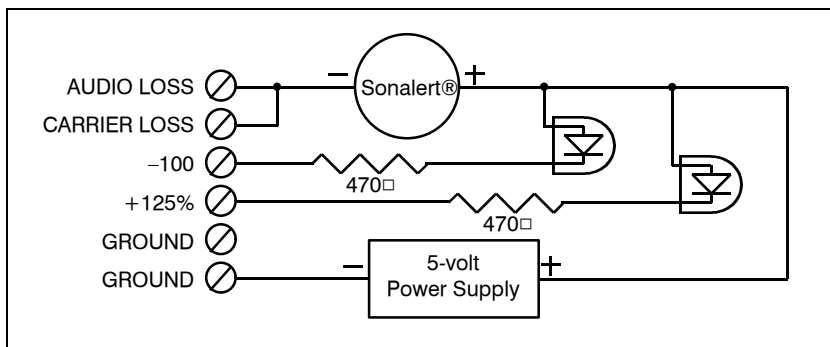

Figure 2 - Remote Alarm Connection Example

SERIAL INTERFACE

The SERIAL INTERFACE DB-9 connector is a bi-directional RS-232 port operating at a data rate of 9600 baud. This port may be connected directly to the serial (COM) port of an IBM-compatible computer, or to a modem for off-premises data transfer using a suitable cable. Cable diagrams are included near the bottom of the third sheet of Schematics, Page 35 in the Appendix.

Software for computer operation of the 520 is shipped with each unit. Refer to Page 16 for installation and operating instructions.

Section III

SETUP AND OPERATION

OPERATIONAL OVERVIEW AND PANEL APPOINTMENTS

This section leads off with an overview of the 520 Mod-Monitor and makes particular reference to front-panel indicators and controls.

BASIC OPERATION OF ALL FUNCTIONS is described and explained in this overview. Whether you subscribe to the idea of reading a Manual first, or simply ‘blasting ahead’ on your own, please at least check these descriptions to verify that our terminology is in agreement with your own understanding. If you call us (especially if you use our toll-free number!) with a question that is answered here, we reserve the right to be very cross with you.

MODULATION DISPLAY

The front-panel bargraph MODULATION readout may be switched with the associated SELECT button to display POS. (positive) modulation, NEG. (negative) modulation, and a relative measurement of the incoming RF level. The display cycles among the three measurement options as the SELECT button is pressed. The green LEDs above the button indicate which function is being monitored.

FCC rules for domestic (US) AM broadcasting (and rules governing other progressive countries) allow *asymmetrical* modulation on the AM band; that is, greater modulation for the positive-going portion of the program audio waveform than for the negative excursion. This practice yields a slight advantage in perceived loudness and station ‘reach.’ When an AM carrier is modulated to +100%, radiated peak power is *four times* the value of an unmodulated carrier. At +125% modulation, the peak carrier power goes to *more than six times* the unmodulated value. -100% (negative) modulation, on the other hand, represents zero power, or complete cutoff of the AM carrier... and that’s as far as it can go.

When cycled to show RF level, the bargraph display gives a relative readout of the incoming carrier strength. In off-air operation, preselector AGC action will cause what looks to be a very non-linear display. Actually, AGC

ADJUSTABLE PEAK FLASHERS

works over several decades of amplitude control to keep the off-air signal in the RF LEVEL RANGE ‘window’ beneath the zero-dB marking on the display scale.

When a direct high level RF input is fed to the 520, a rear-panel control must be adjusted to bring the display into this predetermined range. (See Page 10.)

Whenever the off-air or the high-level input signal falls outside the window, the CARRIER ALARM indicator will light.

The dB scale is included as an aid in checking audio response. 0dB corresponds to 100% carrier modulation.

The two holes above the SET PEAK button allow the user screwdriver access to adjust trip levels for the POS. and NEG. adjustable peak flashers. These flashers may be set anywhere between 80% and 130%. Common practice is to set these just short of absolute modulation limits; this will verify effectiveness of audio peak control. Here’s how they’re set.

Cycle the MODULATION display SELECT button to read POS. peaks, then press the SET PEAK button. The POS. LED will flash rapidly, and the bargraph will then display the trip level of the adjustable positive peak flasher. *While holding down the SET PEAK button*, insert a small screwdriver in the upper hole and set the trip level to a desired value... +120% for instance.

Cycle the SELECT button to read NEG. peaks, then press the SET PEAK button. The NEG. LED will flash rapidly showing that the bargraph is actually displaying the negative flasher trip level. *While holding down the SET PEAK button*, reach through the lower hole and set the negative trip level to the desired value... perhaps -94%.

When the SET PEAK button is released, the bargraph reverts to modulation display.

ALARMS

The four red LED indicators signal out-of-limits station operation. The +125% and -100% indicators may flash *occasionally* during normal program transmission, but frequent or sustained indications warn of definite overmodulation, possibly a misadjustment or failure of the station’s audio processing system.

The CARRIER ALARM indicator will light instantly if the incoming RF level is below (or above!) the requisite value. Check the transmitter as soon as this indicator lights, to make certain that the station is still on the air.

The AUDIO LOSS indicator comes on after about 10 seconds of “dead air.” Transmitter metering may show the station operating normally, though programming may have been interrupted by a failure in the audio path.

HEADPHONE JACK

This front-panel appointment allows the operator to hear recovered monaural audio with a pair of common stereo headphones. This output follows the same NRSC de-emphasis characteristic as the rear-panel PROGRAM AUDIO connector.

USING THE MODEL 520 MOD-MONITOR

Between Section II, which describes installation and connection of the Model 520, and the foregoing discussion of controls and indicators, operation of the Mod-Monitor should be intuitive to any self-respecting broadcast professional. Some cautions and observations are noted here, however.

Co-Channel and Adjacent- Channel Interference

To give accurate modulation readings, the Model 520 must demodulate the *entire* AM signal; that is, carrier and both sidebands. This requires a very broad off-air reception bandwidth. To recover sideband energy for flat audio response to 10kHz, the combined RF/IF bandwidth must be at least 20kHz ($\pm 10\text{kHz}$). Since very steep filters exhibit poor phase response and group delay characteristics, an actual pre-detection bandwidth of 40-50kHz is a more realistic figure to ensure accurate readings.

Interference from another station on the same frequency will affect modulation measurements. This 'co-channel' interference is a particular problem after nightfall, when distant stations are more easily received.

With US broadcast assignments spaced 10kHz apart, program audio components above 5kHz legitimately fall into the spectrum of a first-adjacent (10kHz away) channel. First-adjacent interference can influence modulation readings if the intruding carrier has sufficient strength. Even a second-adjacent (20kHz away) channel can interfere to a measurable extent if NRSC transmission filtering does not limit modulating frequencies to 10kHz, or if the distant transmitter has been allowed to 'splatter' through severe negative overmodulation.

A simple way to identify interference is to listen to the audio output of the Modulation Monitor. Casual listening with a set of headphones plugged into the front-panel jack will reveal interference present in substantial amounts; most probably an amount sufficient to show up as something 'not quite right' on the bargraph display. A good test is to listen in a quiet environment to an amplifier and loudspeaker connected to the Monitor's PROGRAM AUDIO output, preferably during a test period when the carrier is not modulated. Audible artifacts 30dB below full modulation might go unnoticed in the presence of processed program audio, but these can cause a modulation readout error of 3%.

Impulse Noise

Atmospheric disturbances and automobile ignitions used to be the primary source of 'impulse' interference. Nowadays it's light dimmers, motor controllers and other equipment connected to the

AC power line. Just as with interference from other stations, impulse noise is best identified by careful listening.

Interference Solutions

A directional rooftop antenna, such as the optional active ferrite antenna sold by Inovonics, will capture the best possible signal from a remote transmitter site. The 'null' associated with the antenna's directional characteristics can minimize co-channel and adjacent-channel signals, and a quiet antenna location will guard against mains-related interference.

Manual RF Gain Control

Mod-Monitor AGC regulates the incoming RF level for nearly any reception situation. This will be evidenced by the RF (level) bargraph remaining in the RF LEVEL RANGE 'window.' On the odd chance that the incoming RF level is excessive, the AGC might run out of control range. If this happens, the bargraph will rise above the indicated window and the CARRIER ALARM indicator will light. Shortening the antenna should remedy this problem, but a manual RF gain control is provided for special circumstances.

The manual RF gain adjustment, R112, is located under the top cover on the main circuit board a short distance behind the ANTENNA INPUT connector. *This adjustment is normally left at full-clockwise rotation, and only turned in a counterclockwise direction to reduce the incoming signal level.* Should this become necessary in an emergency, slowly rotate R112 counterclockwise until the front-panel RF (level) bargraph display is reduced to the center of the RF LEVEL RANGE 'window.'

Any user adjustment of R112 should be considered a temporary measure. Make a note that the sensitivity has been reduced and return the control to full clockwise when the input signal has been tamed.

REMOTE CONTROL OF THE MODEL 520

Computer and Modem Compatibility

Control software provided with the 520 is written in Visual Basic 5[®]. It runs only under Windows 95[®] or subsequent 32-bit versions of Microsoft's popular operating system for IBM-compatibles. The software enables remote control of the Mod-Monitor, either from a computer connected directly to the 520 or via a modem interface.

Any Hayes-compatible modem *should* permit remote computer control of the Model 520 over an intermediate dial-up telephone circuit. The compatibility issue will be one between the computer's own modem and the remote modem connected to the Mod-Monitor. With full compatibility between the two modems, the interconnection will appear transparent. The link will give the same rapid and effective control over the Monitor as if the computer were connected directly.

Interconnection

A standard serial interconnect cable may be used to connect the Mod-Monitor directly to the serial (COM) port of an IBM-compatible PC. The computer will have either a DB9 or DB25 *male* connector.

If the COM port is a 25-pin connector, use a common 25-pin to 9-pin “mouse” adapter/reducer.

An external modem, on the other hand, will have a DB9 or DB25 *female* connector. This will require an interconnect cable especially configured to connect it with the Model 520.

Schematic Sheet 3, on Page 35, diagrams the several options for interconnect cables between the Model 520 and computer or modem.

Section IV

CIRCUIT DESCRIPTIONS

This section details circuitry of the Inovonics Model 520 AM Modulation Monitor and the optional active antenna. Circuit descriptions refer to three pages of Schematic Diagrams contained in the Appendix, Section V, Pages 33 through 35.

CALIBRATION DISCLAIMER

We do not publish a formal procedure for field alignment and calibration of the Model 520. Although Monitor circuitry has been reduced to seemingly simple proportions, proper adjustment of tuned inductors and other trim controls is crucial to the unit's measurement accuracy. These adjustments require specialized test equipment and calibration fixtures not generally found in the broadcaster's test equipment cabinet. Components and circuitry employed in the 520 are not subject to aging or drift and do not require scheduled or routine calibration or adjustment.

Notwithstanding this caveat, the purpose of each trim control is described in the following Circuit Descriptions, and 'notes' are given concerning the optimum adjustment of each. Adjustment Notes are identified by parentheses around the headings to the left of the text.

CIRCUIT NAVIGATION

Schematic component reference designations have not been assigned in as haphazard a manner as at first it might appear. Instead of annotating the *schematic* in a logical sequence, we instead chose to designate the *components on the circuit board* following their physical placement, top-to-bottom, left-to-right. We expect this practice will prove most useful when troubleshooting, making it easier to locate the physical part after analyzing the diagram.

The Model 520 schematic consists of three sheets covering the main circuit board, the front-panel circuit board, and the optional active antenna. Main-board components begin with the number "1"; i.e.: R1, C1, IC1. Front-panel components are in the five hundred series; i.e.: R501, S501. Components of the optional active antenna are numbered in the 600s, starting with R601, Q601, etc. The few components hard-mounted to the chassis are 700-series parts and are included in the main-board schematics.

The front-panel assembly interconnects with the main board using a short ribbon-cable jumper. J5 on the main board mates with J505 on the front panel assembly.

'FRONT END' (Schematic Sheet 1, Page 33)

Phantom Power Q23 applies current-limited +9VDC to the ANTENNA INPUT (J702) through RF-blocking choke L7. The optional active antenna operates off this phantom power; a random-length of wire simply ignores it.

Manual RF Gain Control The manual RF gain control, R112, is normally left fully clockwise for maximum sensitivity. AGC circuitry regulates RF stage gain automatically for virtually any input signal level. R112 is included as a *temporary solution* to an overload problem. Manual RF gain adjustment is described on Page 16.

Cascode RF Amplifier Q24 and Q25 form a cascode-connected ('totem pole') double-tuned RF stage. The antenna input is shunt-fed to the bottom of L9 and tuned to the incoming carrier frequency by 'varactor' (variable-capacitance diode) VCD2. The second tuned circuit in the collector of Q25 gives further reception selectivity.

Q26 buffers the tuned RF signal and drives the RF input port of the mixer stage, IC13. RF may be interrupted by disconnecting test jumper JMP2 so that a test oscillator signal may be applied directly to the mixer input for alignment of the IF filters.

Local Oscillator Q21 and Q22 comprise the local oscillator. This is a form of the historic Franklin Oscillator configuration (no, not *Ben* Franklin!). The high input impedance of FET Q21 and the high resistance of feedback resistor R91 isolate the tuned circuit from the active gain stages. Oscillator coil L6 is tuned by varactor VCD1. C52, in series with the varactor, maintains the LO frequency offset at 300kHz. The LO is 300kHz *above* the incoming carrier.

Tuning Synthesizer IC12 is a monolithic frequency synthesizer. XTAL1 oscillates at 2.048MHz, which is divided-down internally to generate the 1kHz VCO loop frequency. Tuning is available in 1kHz steps, though the Tuning Charts (Pages 28 and 29) give DIP-switch setups for 10kHz and 9kHz (European) tuning increments.

(Front-End Tuning Notes) Front-end tuning adjustments are made *after* the IF has been aligned.

IC14 derives varactor-diode tuning voltage from the phase detector output of synthesizer IC12. Tuning voltage is measured at the top of C54 (right-hand end of R104). With the DIP switch programmed for a receive frequency of 1710kHz, L6 is tuned for +6VDC. The DIP switch is then reprogrammed for 530kHz, and R96 then adjusted for a reading of -6VDC. Tuning voltage varies between these two values across the band.

In a similar manner, L9 and L10 are adjusted for maximum signal when the Monitor is tuned to 1710kHz, and R120 and R121 for best

530kHz reception. For the most accurate adjustment, monitor AGC voltage at the output of IC10A (right-hand end of R42). This voltage swings from +0.6V (no signal) to -8V (overload). Tune for a peak in the negative voltage, but keep readjusting the *unmodulated* RF generator output to maintain the reading at about -1VDC.

MIXER AND IF (Schematic Sheet 1, Page 33)

IC13 is a monolithic double-balanced mixer. It converts the difference between the incoming carrier and the local oscillator frequencies to a 300kHz *intermediate frequency* (IF).

One single-tuned and two double-tuned IF amplifier stages follow the mixer. The combined shape factors determine the selectivity characteristic and the recovered program audio bandwidth of the Model 520.

Each gain stage consists of a high-impedance JFET device and a bipolar transistor in a 'feedback pair' configuration. This minimizes loading of the tuned circuits and yields a low output impedance to drive the next stage. The first two gain stages have unity voltage gain, the third stage has a voltage gain of about 10dB. Overall IF gain is considerably higher than these numbers would suggest as each double-tuned filter exhibits a large impedance-transformation voltage gain.

(IF Tuning Notes)

Test Jumper JP2 is removed, and the *unmodulated* RF generator is connected to the left-hand jumper terminal. This routes the test signal directly into the RF port of mixer IC13. AGC voltage is monitored with a voltmeter at the output of IC10A (right-hand end of R42). This voltage swings from +0.6V (no signal) to -8V (overload). IF coils are tuned for a negative voltage peak, but the RF generator output must constantly be readjusted to maintain the reading at about -1VDC.

The local oscillator is tuned to 1300kHz (actual) by programming the DIP switch for a receive frequency of 1000kHz. This gives a 300kHz IF output from the mixer.

With an RF generator frequency of exactly 1000kHz, L5 is tuned for a peak (greatest negative voltage). Generator frequency is then reset to exactly 1013kHz, and L2 and L4 are tuned for a peak. With the generator reset to exactly 897kHz, L1 and L3 are peaked. Once this has been completed, L5 is then retuned to balance IF response at the passband edges. This means equal amplitude at 1010kHz and 990kHz. First set the generator output amplitude for -1 volt of AGC at 1010kHz, then change the generator frequency to 990kHz and carefully adjust L5 to approach the same DC voltage. Of course any readjustment of L5 will change the reading at both frequencies, so you'll have to go back-and-forth a few times. The idea is to eventually tweak it for the same AGC voltage for each frequency. (Now don't you wish you'd left it alone?)

AM DETECTOR AND AGC (Schematic Sheet 1, Page 33)

HIGH LEVEL Input S3 switches between the output of the IF amplifier and the rear-panel HIGH LEVEL input jack, J701. Though off-air operation is AGC-stabilized for input signal variations, 'direct' samples from the transmitter require adjustment of the HIGH LEVEL INPUT ADJUST control, R81, to center the bargraph display in the RF LEVEL RANGE window.

Phase Inverter Q9 and Q10 form an emitter-coupled phase inverter to give push-pull drive to the full-wave detector. This configuration is patterned after the 'longtail pair' phase inverter, popular in the days of vacuum-tube hi-fi power amplifiers. The advantage of this circuit is that both outputs exhibit the same impedance characteristics.

Detector UK circuit guru Ian Hickman has made an exhaustive search for the 'perfect diode'; that is, one without a forward drop and with linear small-signal rectification. His article "Tweaking the Diode Detector" appeared in the February, 1995 issue of *Wireless World* magazine, and subsequently was reprinted in *Hickman's Analog and RF Circuits*, published in the UK by Newnes (ISBN 0 7506 3742 0). The Model 520 detector owes thanks to Mr. Hickman's published experiments in correcting diode non-linearities.

'Transdiodes' Q11 and Q12 peak-rectify the split-phase RF input. Q13 is a bias source to track rectifier temperature coefficients. Q14 in the feedback path of IC11, along with trim control R67, establishes a nonlinear amplifier gain just at the onset of rectification to compensate for the turn-on characteristics of Q11 and Q12.

IC11A is a second-order low-pass filter to remove IF or carrier frequency components from the rectifier output. Full-wave detection reduces ripple and relaxes the attendant filtering requirements. Thus this simple circuit, with its gentle rolloff and splendid phase response, is thoroughly adequate.

(Detector Adjustment Notes) The two detector trim adjustments are set with an RF generator feeding the Mod-Monitor's rear-panel HIGH LEVEL INPUT. The generator is tuned to 1000kHz and modulated with a 1kHz sinewave to about 95% modulation. The generator output level (or the Monitor's HIGH LEVEL INPUT GAIN control) is set for a front-panel RF bargraph reading centered in the RF LEVEL RANGE window.

Monitor the output of the low-pass filter stage, IC11A (right-hand end of R50), with both a DC voltmeter and an audio distortion analyzer. Adjust R67 for a null in the total harmonic distortion reading (normally a bit below 0.3%). Disconnect the RF generator and set R52 for zero volts DC at the monitor point. The two controls have a certain degree of interaction that will require several back-and-forth tries before the two adjustments coincide.

Carrier Level Recovery Differential stage IC10B recovers a DC voltage proportional to the incoming carrier level by subtracting the AC component from the detector output. This DC voltage, devoid of modulation artifacts, is

further summed with the detector output in IC9B to recover only the modulation information. The output of IC9B is positive-going, (with reference to ground) for *positive* program peaks. IC9A inverts this to create a positive-going waveform (with reference to ground) for *negative* program peaks.

AGC Amplifier The carrier DC component from IC10B is fed to AGC amplifier stage IC10A. Offset bias through R43 drives the output of this stage positive, CR10 limits the positive excursion to +0.6V. When carrier-derived DC reaches a threshold level of approximately +4VDC, IC10A becomes a linear amplifier. Increasing carrier level drives the output negative, and the resultant negative-going AGC is applied to Q25 of the cascode RF amplifier stage to bring about RF gain reduction.

PEAK INTEGRATION AND HOLD (Schematic Sheet 2, Page 34)

Positive program peaks from IC9B are buffered by IC7B to charge C20 through CR9 and R26. Integration afforded by R26 and C20 is a good deal less than might be expected from the R/C time constant as the integrator is included in the feedback path of IC7B.

The output of IC7B sits at the negative rail except to charge C20 to a higher voltage than its present value. As C20 charges, the output of IC7B toggles from the negative to the positive supply rail. This turns on Q8, discharging C19 to the negative rail and holding Q7 off. When IC7B toggles negative again, Q8 turns off and C19 begins to charge through R21 and R22. When the junction of these resistors reaches +0.6V, Q7 turns on to discharge C20. The charging time of C19, approximately 0.3 seconds, delays the discharge of C20 and furnishes the peak-hold function that makes even the quickest program transient measurable.

Negative program peaks, which have been rendered positive-going by unity-gain inverter IC9A, have an identical circuit for peak integration and hold. The output of IC9A also provides program audio for monitoring purposes.

Program Audio Recovery Carrier modulation from the output of IC9A is fed to audio line-driver stage IC8B. C21 and R35 impart the truncated 75-microsecond NRSC de-emphasis characteristic to the program signal. Moving jumper JMP1 as described on Page 11 defeats de-emphasis. When C21 and R35 are out of the circuit, demodulated audio has flat response. Unity-gain inverter IC8A drives the opposite output polarity, the balanced PROGRAM AUDIO OUTPUT bridging the two output amplifiers. IC8B also drives the front-panel PHONES jack.

(Peak Adjustment Notes) R28 and R19 are calibration adjustments for positive and negative peak measurements, respectively. Each control is adjusted so that the corresponding front-panel MODULATION readout will indicate precisely 100% when the carrier is fully modulated. These adjustments require an RF generator with its own very accurate

modulation calibration. An oscilloscope display of the modulation envelope, or even the historic 'trapezoid' AM modulation pattern, is *insufficiently precise* for making accurate adjustments!

BARGRAPH DISPLAY AND MISCELLANEOUS FUNCTIONS (Schematic Sheets 3 & 2, Pages 35 & 34)

The 520 makes efficient use of two integrated circuit 'PICs,' or Peripheral Interface Controllers. These are IC502 on the front-panel circuit board and IC5 on the main board.

The PIC is a simple, single-chip microcontroller meant for uncomplicated logic and control functions. The two used in the Model 520 are factory-programmed to poll front-panel pushbutton switches, to light status and alarm indicator LEDs, and to manage RS-232 serial communications. IC502 also performs analog-to-digital conversion in connection with the MODULATION bargraph display and the peak flashers.

Bargraph Display Positive and negative modulation peaks from IC7A and IC6A are applied to two analog inputs of IC502. DC voltage corresponding to the carrier level is routed to a third input as a reference for modulation measurement. A serial stream of digital level values and timing/clocking data is fed to matrix display driver IC501. The driver translates this into a bargraph readout of the instantaneous positive or negative peak value, or of the incoming carrier level.

Two remaining analog inputs of IC502 monitor static DC voltages derived from the incoming carrier level reference and scaled by R507 and R508. These two front-panel adjustments are associated with the adjustable peak flashers.

Alarms The PIC generates an alarm whenever modulation exceeds legal limits, when audio modulation is absent for a period of time, and when the resting carrier level goes outside its normal range. Front-panel LED indicators are lighted directly, and Q1, Q2, Q3 and Q4 on the main circuit board saturate to ground to drive outboard indicators.

Serial Data Interface Modulation and other data collected by IC502 are transmitted serially to a second PIC, IC5 on the main circuit board. The sole function of IC5 is to format these data for RS-232 serial communication with a computer or a modem link.

IC4 is a transmit/receiver driver that shifts PIC logic levels to the appropriate RS-232 bipolar standard.

Power Supply The Model 520 utilizes ± 9 -volt supplies for op-amps, RF stages and other analog circuitry, and a +5-volt supply for digital logic. These three sources are each regulated by a '3-terminal' linear voltage regulator: IC1 for +9 volts, IC3 for -9 volts, and IC2 for +5 volts.

Power transformer T1 has dual primary windings. These may be switched in parallel or in series to accommodate 115V or 230V mains, respectively.

OPTIONAL ACTIVE ANTENNA (Schematic Sheet 1, Page 33)

The active antenna optionally available from Inovonics was designed as a companion for the Model 520 Mod-Monitor. It consists of a ferrite-rod antenna coil with an integral preamplifier. Construction uses common PVC pipe to make it entirely waterproof for rooftop installation. The antenna is a novel broadband design requiring no tuning. It is automatically phantom-powered when connected to the Model 520 Mod-Monitor.

Q601 and Q602 comprise a very simple, 2-stage op-amp. Complimentary emitter-followers Q603 and Q604 provide current gain to drive as much as 200 feet of coaxial cable connecting the antenna with the Monitor. Power for the preamplifier is 'picked off' the coax through L601, and C605 blocks DC from the output stage.

The inverting input of the preamp is the emitter of Q601. The ferrite-core antenna coil is connected between this input and ground. Negative feedback is returned directly to the ungrounded side of the antenna coil. This junction becomes a 'zero impedance' current-summing node. Consequently the antenna coil operates into a virtual short-circuit and cannot exhibit self-resonance or other tuning effects.

The potential bandwidth of this design is quite wide, theoretically limited to about 3kHz on the low end by DC resistance of the antenna coil, and to a maximum operating frequency of 20MHz due to transistor characteristics and losses in the ferrite core. For our purposes, L602 and C605 are included to offer first-order band-pass filtering. This limits sensitivity to the medium-wave broadcast band.

Section VI

APPENDIX

This section of the Model 520 Manual contains Tuning Charts to program the receive frequency of the Model 520, Parts Lists and Schematic Diagrams, and an explanation of Inovonics' liberal Warranty Policy.

TUNING CHART 1

10kHz (US) Channel Spacings

kHz	A	B	C	D	E	F	G	H	I	J	K	kHz	A	B	C	D	E	F	G	H	I	J	K	kHz	A	B	C	D	E	F	G	H	I	J	K
530	1	0	0	0	0	0	1	1	0	0	1	930	1	0	0	0	1	1	0	0	1	1	0	1330	1	0	0	0	0	1	0	1	1	0	0
540	1	1	1	0	1	1	0	1	0	0	1	940	1	1	1	0	0	1	0	0	1	1	0	1340	1	1	1	0	1	0	0	1	1	0	0
550	1	0	1	1	0	1	0	1	0	0	1	950	1	0	1	1	1	0	0	0	1	1	0	1350	1	0	1	1	0	0	0	1	1	0	0
560	1	1	0	0	0	1	0	1	0	0	1	960	1	1	0	0	1	0	0	0	1	1	0	1360	1	1	0	0	0	0	0	1	1	0	0
570	1	0	0	1	1	0	0	1	0	0	1	970	1	0	0	1	0	0	0	0	1	1	0	1370	1	0	0	1	1	1	1	0	1	0	0
580	1	1	1	1	0	0	0	1	0	0	1	980	1	1	1	1	1	1	1	0	1	0	1380	1	1	1	1	0	1	1	0	1	0	0	
590	1	0	1	0	0	0	0	1	0	0	1	990	1	0	1	0	1	1	1	1	0	1	0	1390	1	0	1	0	0	1	1	0	1	0	0
600	1	0	0	0	1	1	1	1	0	1	1	1000	1	1	0	1	0	1	1	1	0	1	1400	1	1	0	1	1	0	1	0	1	0	0	
610	1	0	0	0	1	1	1	0	0	0	1	1010	1	0	0	0	0	1	1	1	0	1	0	1410	1	0	0	0	1	0	1	0	1	0	0
620	1	1	1	0	0	1	1	0	0	0	1	1020	1	1	1	0	1	0	1	1	0	1	1420	1	1	1	0	0	0	1	0	1	0	0	
630	1	0	1	1	1	0	1	0	0	0	1	1030	1	0	1	1	0	0	1	1	0	1	0	1430	1	0	1	1	1	1	0	0	1	0	0
640	1	1	0	0	1	0	1	0	0	0	1	1040	1	1	0	0	0	0	1	1	0	1	1440	1	1	0	0	1	1	0	0	1	0	0	
650	1	0	0	1	0	0	1	0	0	0	1	1050	1	0	0	1	1	1	0	1	0	1	0	1450	1	0	0	1	0	1	0	0	1	0	0
660	1	1	1	1	1	1	0	0	0	0	1	1060	1	1	1	1	0	1	0	1	0	1	1460	1	1	1	1	0	0	0	1	0	0		
670	1	0	1	0	1	1	0	0	0	0	1	1070	1	0	1	0	0	1	0	1	0	1	0	1470	1	0	1	0	1	0	0	0	1	0	0
680	1	1	0	1	0	1	0	0	0	0	1	1080	1	1	0	1	1	0	0	1	0	1	1480	1	1	0	1	0	0	0	0	1	0	0	
690	1	0	0	0	0	1	0	0	0	0	1	1090	1	0	0	0	1	0	0	1	0	1	0	1490	1	0	0	0	0	0	0	0	1	0	0
700	1	1	1	0	1	0	0	0	0	0	1	1100	1	1	1	0	0	0	0	1	0	1	1500	1	1	1	0	1	1	1	0	0	0	0	
710	1	0	1	1	0	0	0	0	0	0	1	1110	1	0	1	1	1	1	1	0	0	1	0	1510	1	0	1	1	0	1	1	1	0	0	0
720	1	1	0	0	0	0	0	0	0	0	1	1120	1	1	0	0	1	1	1	0	0	1	1520	1	1	0	0	0	1	1	1	0	0	0	
730	1	0	0	1	1	1	1	1	1	1	0	1130	1	0	0	1	0	1	1	0	0	1	0	1530	1	0	0	1	1	0	1	1	0	0	0
740	1	1	1	1	0	1	1	1	1	1	0	1140	1	1	1	1	1	0	1	0	0	1	1540	1	1	1	1	0	0	1	1	0	0	0	
750	1	0	1	0	0	1	1	1	1	1	0	1150	1	0	1	0	1	0	1	0	0	1	0	1550	1	0	1	0	0	0	1	1	0	0	0
760	1	1	0	1	1	0	1	1	1	1	0	1160	1	1	0	1	0	0	1	0	0	1	1560	1	1	0	1	1	1	0	1	0	0	0	
770	1	0	0	0	1	0	1	1	1	1	0	1170	1	0	0	0	0	0	1	0	0	1	0	1570	1	0	0	0	1	1	0	1	0	0	0
780	1	1	1	0	0	0	1	1	1	1	0	1180	1	1	1	0	1	1	0	0	0	1	1580	1	1	1	0	0	1	0	1	0	0	0	
790	1	0	1	1	1	1	0	1	1	1	0	1190	1	0	1	1	0	1	0	0	0	1	0	1590	1	0	1	1	1	0	0	1	0	0	0
800	1	1	0	0	1	1	0	1	1	1	0	1200	1	1	0	0	0	1	0	0	0	1	1600	1	1	0	0	1	0	0	1	0	0	0	
810	1	0	0	1	0	1	0	1	1	1	0	1210	1	0	0	1	1	0	0	0	0	1	0	1610	1	0	0	1	0	0	0	1	0	0	0
820	1	1	1	1	1	0	0	1	1	1	0	1220	1	1	1	1	0	0	0	0	0	1	0	1620	1	1	1	1	1	1	0	0	0	0	
830	1	0	1	0	1	0	0	1	1	1	0	1230	1	0	1	0	0	0	0	0	0	1	0	1630	1	0	1	0	1	1	1	0	0	0	0
840	1	1	0	1	0	0	0	1	1	1	0	1240	1	1	0	1	1	1	1	1	1	0	1640	1	1	0	1	0	1	1	0	0	0	0	
850	1	0	0	0	0	0	0	1	1	1	0	1250	1	0	0	0	1	1	1	1	1	0	0	1650	1	0	0	0	0	1	1	0	0	0	0
860	1	1	1	0	1	1	1	0	1	1	0	1260	1	1	1	0	0	1	1	1	1	0	1660	1	1	1	0	1	0	1	0	0	0	0	
870	1	0	1	1	0	1	1	0	1	1	0	1270	1	0	1	1	1	0	1	1	1	0	0	1670	1	0	1	1	0	0	1	0	0	0	0
880	1	1	0	0	0	1	1	0	1	1	0	1280	1	1	0	0	1	0	1	1	1	0	1680	1	1	0	0	0	0	1	0	0	0	0	
890	1	0	0	1	1	0	1	0	1	1	0	1290	1	0	0	1	0	0	1	1	1	0	0	1690	1	0	0	1	1	1	0	0	0	0	0
900	1	1	1	1	0	0	1	0	1	1	0	1300	1	1	1	1	1	1	0	1	1	0	1700	1	1	1	1	0	1	0	0	0	0	0	
910	1	0	1	0	0	0	1	0	1	1	0	1310	1	0	1	0	1	1	0	1	1	0	0	1710	1	0	1	0	0	1	0	0	0	0	0
920	1	1	0	1	1	1	0	0	1	1	0	1320	1	1	0	1	0	1	0	1	1	0													

TUNING CHART 2

9kHz (European) Channel Spacings

kHz	A	B	C	D	E	F	G	H	I	J	K	kHz	A	B	C	D	E	F	G	H	I	J	K	kHz	A	B	C	D	E	F	G	H	I	J	K
531	0	0	0	0	0	0	1	1	0	0	1	891	0	0	0	1	1	0	1	0	1	1	0	1251	0	0	0	0	1	1	1	1	1	0	0
540	1	1	1	0	1	1	0	1	0	0	1	900	1	1	1	0	0	1	0	1	1	0	1260	1	1	1	0	0	1	1	1	1	0	0	
549	0	1	1	1	0	1	0	1	0	0	1	909	0	1	1	0	0	0	1	0	1	1	0	1269	0	1	1	1	1	0	1	1	1	0	0
558	1	0	1	0	0	1	0	1	0	0	1	918	1	0	1	1	1	0	0	1	1	0	1278	1	0	1	0	1	0	1	1	1	0	0	
567	0	0	1	1	1	0	0	1	0	0	1	927	0	0	1	0	1	1	0	0	1	1	0	1287	0	0	1	1	0	0	1	1	1	0	0
576	1	1	0	0	1	0	0	1	0	0	1	936	1	1	0	1	0	1	0	0	1	1	1296	1	1	0	0	0	0	1	1	1	0	0	
585	0	1	0	1	0	0	0	1	0	0	1	945	0	1	0	0	0	1	0	0	1	1	0	1305	0	1	0	1	1	1	0	1	1	0	0
594	1	0	0	0	0	0	0	1	0	0	1	954	1	0	0	1	1	0	0	0	1	1	1314	1	0	0	0	1	1	0	1	1	0	0	
603	0	0	0	1	1	1	1	0	0	0	1	936	0	0	0	0	1	0	0	0	1	1	0	1323	0	0	0	1	0	1	0	1	1	0	0
612	1	1	1	1	0	1	1	0	0	0	1	972	1	1	1	0	0	0	0	0	1	1	1332	1	1	1	1	0	0	1	1	0	0		
621	0	1	1	0	0	1	1	0	0	0	1	981	0	1	1	1	1	1	1	0	1	0	1341	0	1	1	0	1	0	0	1	1	0	0	
630	1	0	1	1	1	0	1	0	0	0	1	990	1	0	1	0	1	1	1	1	0	1	1350	1	0	1	1	0	0	0	1	1	0	0	
639	0	0	1	0	1	0	1	0	0	0	1	999	0	0	1	1	0	1	1	0	1	0	1359	0	0	1	0	0	0	0	1	1	0	0	
648	1	1	0	1	0	0	1	0	0	0	1	1008	1	1	0	0	0	1	1	1	0	1	1368	1	1	0	1	1	1	1	0	1	0	0	
957	0	1	0	0	0	0	1	0	0	0	1	1017	0	1	0	1	1	0	1	1	0	1	1377	0	1	0	0	1	1	1	0	1	0	0	
666	1	0	0	1	1	1	0	0	0	0	1	1026	1	0	0	0	1	0	1	1	0	1	1386	1	0	0	1	0	1	1	0	1	0	0	
675	0	0	0	0	1	1	0	0	0	0	1	1035	0	0	0	1	0	0	1	1	0	1	1395	0	0	0	0	0	1	1	0	1	0	0	
684	1	1	1	0	0	1	0	0	0	0	1	1044	1	1	1	1	1	0	1	0	1	1404	1	1	1	0	1	0	1	0	1	0	0		
693	0	1	1	1	1	0	0	0	0	0	1	1053	0	1	1	0	1	1	0	1	0	1	1413	0	1	1	1	0	0	1	0	1	0	0	
702	1	0	1	0	1	0	0	0	0	0	1	1062	1	0	1	1	0	1	0	1	0	1	1422	1	0	1	0	0	0	1	0	1	0	0	
711	0	0	1	1	0	0	0	0	0	0	1	1071	0	0	1	0	0	1	0	1	0	1	1431	0	0	1	1	1	1	0	0	1	0	0	
720	1	1	0	0	0	0	0	0	0	0	1	1080	1	1	0	1	1	0	0	1	0	1	1440	1	1	0	0	1	1	0	0	1	0	0	
729	0	1	0	1	1	1	1	1	1	1	0	1089	0	1	0	0	1	0	0	1	0	1	1449	0	1	0	1	0	1	0	0	1	0	0	
738	1	0	0	0	1	1	1	1	1	1	0	1098	1	0	0	1	0	0	0	1	0	1	1458	1	0	0	0	0	1	0	0	1	0	0	
747	0	0	0	1	0	1	1	1	1	1	0	1107	0	0	0	0	0	0	0	1	0	1	1467	0	0	0	1	1	0	0	1	0	0		
756	1	1	1	1	1	0	1	1	1	1	0	1116	1	1	1	0	1	1	1	0	0	1	1476	1	1	1	1	0	0	0	0	1	0	0	
765	0	1	1	0	1	0	1	1	1	1	0	1125	0	1	1	1	0	1	1	0	0	1	1485	0	1	1	0	0	0	0	0	1	0	0	
774	1	0	1	1	0	0	1	1	1	1	0	1134	1	0	1	0	0	1	1	0	0	1	1494	1	0	1	1	1	1	1	0	0	0		
783	0	0	1	0	0	0	1	1	1	1	0	1143	0	0	1	1	1	0	1	0	0	1	1503	0	0	1	0	1	1	1	1	0	0	0	
792	1	1	0	1	1	1	0	1	1	1	0	1152	1	1	0	0	1	0	1	0	0	1	1512	1	1	0	1	0	1	1	1	0	0	0	
801	0	1	0	0	1	1	0	1	1	1	0	1161	0	1	0	1	0	0	1	0	0	1	1521	0	1	0	0	0	1	1	1	0	0	0	
810	1	0	0	1	0	1	0	1	1	1	0	1170	1	0	0	0	0	0	1	0	0	1	1530	1	0	0	1	1	0	1	1	0	0	0	
819	0	0	0	0	0	1	0	1	1	1	0	1179	0	0	0	1	1	1	0	0	0	1	1539	0	0	0	0	1	0	1	1	0	0	0	
828	1	1	1	0	1	0	0	1	1	1	0	1188	1	1	1	1	0	1	0	0	0	1	1548	1	1	1	0	0	0	1	1	0	0	0	
837	0	1	1	1	0	0	0	1	1	1	0	1197	0	1	1	0	0	1	0	0	0	1	1557	0	1	1	1	1	1	0	1	0	0	0	
846	1	0	1	0	0	0	0	1	1	1	0	1206	1	0	1	1	1	0	0	0	0	1	1566	1	0	1	0	1	1	0	1	0	0	0	
855	0	0	1	1	1	1	1	0	1	1	0	1215	0	0	1	0	1	0	0	0	0	1	1575	0	0	1	1	0	1	0	1	0	0	0	
864	1	1	0	0	1	1	1	0	1	1	0	1224	1	1	0	1	0	0	0	0	0	1	1584	1	1	0	0	0	1	0	1	0	0	0	
873	0	1	0	1	0	1	1	0	1	1	0	1233	0	1	0	0	0	0	0	0	0	1	1593	0	1	0	1	1	0	0	1	0	0	0	
882	1	0	0	0	0	1	1	0	1	1	0	1242	1	0	0	1	1	1	1	1	1	0	1602	1	0	0	0	1	0	0	1	0	0	0	

PARTS LIST

EXPLANATION OF PARTS LISTINGS

This section of the Manual contains listings of component parts used in the Inovonics Model 520 AM Modulation Monitor. These are listed either in general 'generic' groupings, or specifically by schematic component reference designation. The listing may specify a particular manufacturer, or it may not. When no manufacturer is named, the term "open mfr." advises that any manufacturer's product is acceptable, so long as it carries the proper generic part number.

If a particular component is not listed at all, this means that we do not consider it a typical replacement item. Should you have legitimate need for an unlisted part, call, write or FAX the factory with a brief description. We'll do our best to figure out what you're talking about and get it on its way to you quickly.

PARTS LISTING

Unless specifically noted by component reference designation below, **capacitors** are identified and specified as follows:

- a) Capacitors shown schematically as **non-polarized** are in the 100pF to 0.47 μ F range. Whole number values are picofarads, decimal values with leading zeroes are microfarads. All values are $\pm 5\%$, 50VDC or better. The style used in the 520 is the "minibox" package with a lead spacing of 0.2 inch. **Preferred part:** Wima MKS-2 or FKC-2 series. **Alternates:** CSF-Thompson IRD series or Roederstein KT-1808 or KT-1817 series.
- b) Capacitors shown schematically as **polarized** (1.0 μ F and above) are radial-lead electrolytics, value per schematic, 25VDC; (open mfr.).

C1,2	Capacitor, Ceramic Disc "Safety" Mains Bypass, .0047 μ F, 440VAC; Murata/Erie DE7150 F 472M VA1-KC (preferred)
C3,4	Capacitor, Electrolytic, axial leads, 1000 μ F, 35VDC; (open mfr.)
C13- 16,24,29, 38,39,44,47, 48,50,51, 53,55-59,63, 62-72,502, 504,601-603	Capacitor, Monolithic Ceramic, 0.1 μ F, 0.1" lead spacing; (open mfr.)
C25	Capacitor, Electrolytic, radial-leads, 220 μ F, 10VDC; (open mfr.)
C503	Capacitor, Electrolytic, radial-leads, 1000 μ F, 10VDC; (open mfr.)
CR1-7	Diode, Silicon Rectifier; (open mfr.) 1N4005

CR8-13, 601,602	Diode, Silicon Signal; (open mfr.) 1N4151 or equiv.
CRES501 F1	Ceramic Resonator, 4MHz; Mouser 520-ZTT400MG Fuseholder, PC-mounting; Littlefuse 345-101-010 with 345-101-020 Cap for ¼-inch (U.S.) fuses, or 345-121-020 Cap for 5mm (European) fuses. (Fuse is normal “fast-blow” type in value specified on rear panel per mains voltage.)
I501-504	10-Segment LED-bar display module, green; Kingbright DC-10GWA
I505	10-Segment LED-bar display module, yellow; Kingbright DC-10YWA
I506	10-Segment LED-bar display module, red; Kingbright DC-10EWA
I507-509	LED Indicator, pastel green, T-1 package; Stanley MPG 3878S
I510,511	LED Indicator, pastel yellow, T1 package; Stanley MAY 3378S
I512-515	LED Indicator, pastel red, T-1¾ package; Stanley MVR 5374X
IC1,2	Integrated Cct.; (open mfr.) LM317-T (Uses Aavid 574602 B03700 Heat Fin)
IC3	Integrated Cct.; (open mfr.) LM337-T (Uses Aavid 574602 B03700 Heat Fin)
IC4	Integrated Cct.; Maxim MAX232ACPE
IC5	Integrated Cct.; <i>SPECIAL FACTORY-PROGRAMMED “PIC,”</i> type 16C671. Order by designation and reference Model 520.
IC6-11,14	Integrated Cct.; (open mfr.) LF353N
IC12	Integrated Cct.; Motorola MC145151
IC13	Integrated Cct.; (open mfr.) LM1496/MC1496
IC501	Integrated Cct.; Maxim MAX7219CNG
IC502	Integrated Cct.; <i>SPECIAL FACTORY-PROGRAMMED “PIC,”</i> type 16C72. Order by designation and reference Model 520.
J1	AC Mains Connector, PC-mounting; Switchcraft EAC303
J2	Connector, 9-pin “D-Sub” female, PC-mounting; (open mfr.)
J3	Connector, 6-position wiring strip; Weco 121-M-211/06 header with 121-A-111/06 removable screw-terminal plug
J4	Connector, XLR male; Neutrik NC3MK-H
J6	Headphone Jack; Switchcraft RN112BCP
J701	Connector, BNC chassis receptacle; Amphenol 31-221
J702	Connector, F chassis receptacle; Mouser 16SF061
JMP1,2	Shorting shunt; Robinson-Nugent HPS-02-G or equivalent
L1-5	Inductor, 1mH variable; (Toko 7PA series) Digi-Key TK3201-ND
L6,9,10	Inductor, 220µH variable; (Toko 7PH series) Digi-Key TK2421-ND
L7	Inductor, 1mH; Mouser 43HH103
L8,602	Inductor, 10µH; Mouser 43LS105
L501	Inductor, 330µH high-current; Renco RL1952
L601	Inductor, 47µH; (Miller 78F series) Digi-Key M7833-ND
Q1- 8,11,12,13	Transistor, NPN; (open mfr.) 2N5088
Q9,10,601, 602,604	Transistor, NPN; (open mfr.) MPS6521
Q14,15,17, 19,22,603	Transistor, PNP; (open mfr.) MPS6523
Q16,18,20, 21,24-26	Transistor, JFET; (open mfr.) 2N3819
Q23	Transistor, PNP power; (open mfr.) MJE350

All resistors are specified as follows:

- a) **Fixed resistors** with schematic values carried to decimal places implying a 1% tolerance (*example*: 100.0, 3.01K, 15.0K, 332K) are ¼-watt, 1% metal film type.
- b) **Fixed resistors** with schematic values typical of 5% tolerance (*example*: 220, 3.3k, 10K, 270K) are ¼-watt, 5% carbon film type.
- c) **Circuit Board Trimming Potentiometers** (single-turn) are Tokos GF06U1 series.

R81	Multi-Turn Trimpot, 1K; Tocos RJC097P series
S1	Switch, DPDT Slide, Voltage Selector; C&K V202-12-MS-02-QA
S2	Switch, 12-position DIP; Grayhill 76SB12
S3	Switch, SPST Toggle; C&K 7101-M-D9-A-B-E
S501,502	Switch, SPDT Momentary Pushbutton; ITT D6-04-01, with F14-04 gray cap
S701	Switch, Power Rocker; Carling RA 911-RB-O-N
T1	Power Transformer, PC-mounting; Signal IF-14-20 (preferred) or Signal LP-20-600 or direct cross-reference
VCD1,2,3	‘Varicap’ tuning diode; Toko KV1235Z (matched trio)
XTAL1	Crystal, 2.048MHz, HC-49/U holder; Mouser 520-HCA204-12

MAIL-ORDER COMPONENT SUPPLIERS

The following electronic component distributors have proven themselves reputable suppliers of small quantities of replacement parts for professional equipment.

|| The temptation to use cross-referenced hobbyist
|| or TV-repair-shop ‘direct replacement parts’
|| (ha!) should be avoided! ||

Any semiconductor, IC, capacitor, resistor or connector used in the Model 520 is *probably* available from one or more of these firms. Each supplier publishes a full-line catalog, available free for the asking. Minimum-order restrictions may apply, and export orders may be somewhat difficult. (Call us, we’ll sneak them to you.)

Mouser Electronics — Call (800) 346-6873

Digi-Key Corporation — Call (800) 344-4539

ACTIVE (div. of Future Electronics) — Call (800) 677-8899

Allied Electronics (div. of Avnet) — Call (800) 433-5700

INOVONICS WARRANTY

- I **TERMS OF SALE:** Inovonics products are sold with an understanding of “full satisfaction”; that is, full credit or refund will be issued for products sold as new if returned to the point of purchase within 30 days following their receipt, provided that they are returned complete and in an “as shipped” condition.
- II **CONDITIONS OF WARRANTY:** The following terms apply unless amended *in writing* by Inovonics, Inc.
- A. Warranty Registration Card supplied with product *must* be completed and returned to Inovonics within 10 days of delivery.
 - B. Warranty applies only to products sold “as new.” It is extended only to the original end-user and may not be transferred or assigned without prior written approval by Inovonics.
 - C. Warranty does not apply to damage caused by misuse, abuse, accident or neglect. Warranty is voided by unauthorized attempts at repair or modification, or if the serial identification has been removed or altered.
- III **TERMS OF WARRANTY:** Inovonics, Inc. products are warranted to be free from defects in materials and workmanship.
- A. Any discrepancies noted within 90 days of the date of delivery will be repaired free of charge, or the equipment will be replaced with a new or remanufactured product at Inovonics’ option.
 - B. Additionally, parts for repairs required between 90 days and one year from the date of delivery will be supplied free of charge. Labor for factory installation of such parts will be billed at the prevailing “shop labor rate.”
- IV **RETURNING GOODS FOR FACTORY REPAIR:**
- A. Equipment will not be accepted for Warranty or other repair without a Return Authorization (RA) number issued by Inovonics prior to its return. An RA number may be obtained by calling the factory. The number should be prominently marked on the outside of the shipping carton.
 - B. Equipment must be shipped prepaid to Inovonics. Shipping charges will be reimbursed for valid Warranty claims. Damage sustained as a result of improper packing for return to the factory is not covered under terms of the Warranty and may occasion additional charges.